

JUKI

1-Needle Lockstitch Unison Feed Industrial
Sewing Machine With Reverse Feed

一本針本縫総合送りミシン(返し縫付)

LU-562

1-Needle Lockstitch Unison Feed Industrial
Sewing Machine With a Large Bobbin

一本針本縫総合送り、大ボビン付ミシン

LU-563

PARTS LIST

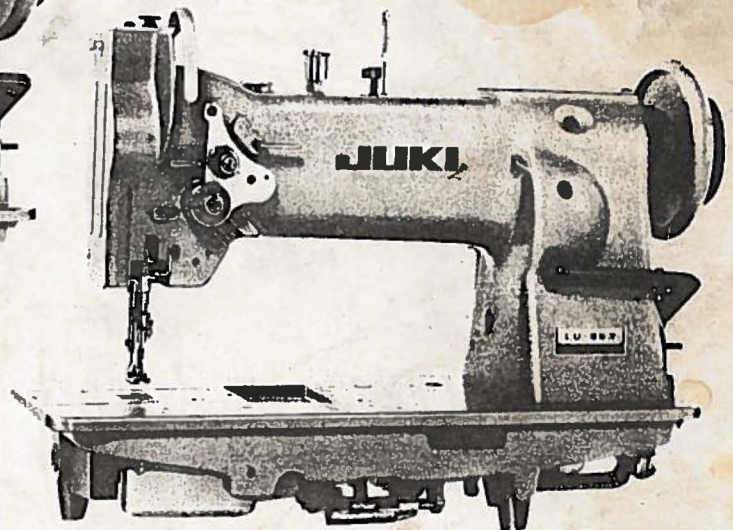
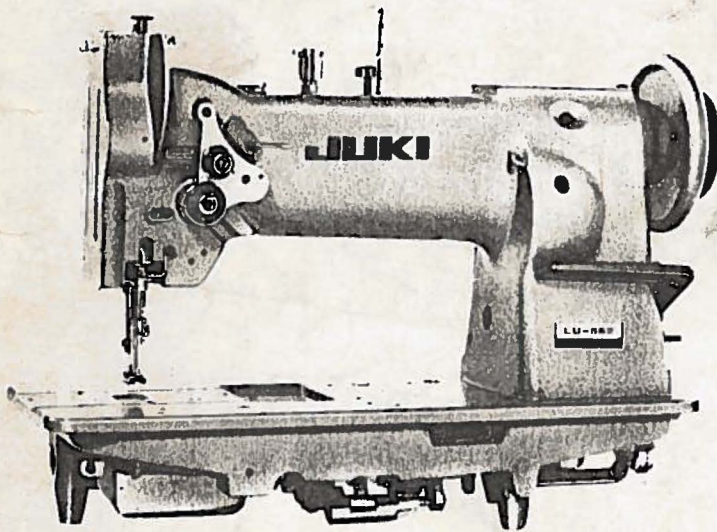

BE5620TOPJA

No 0026-08

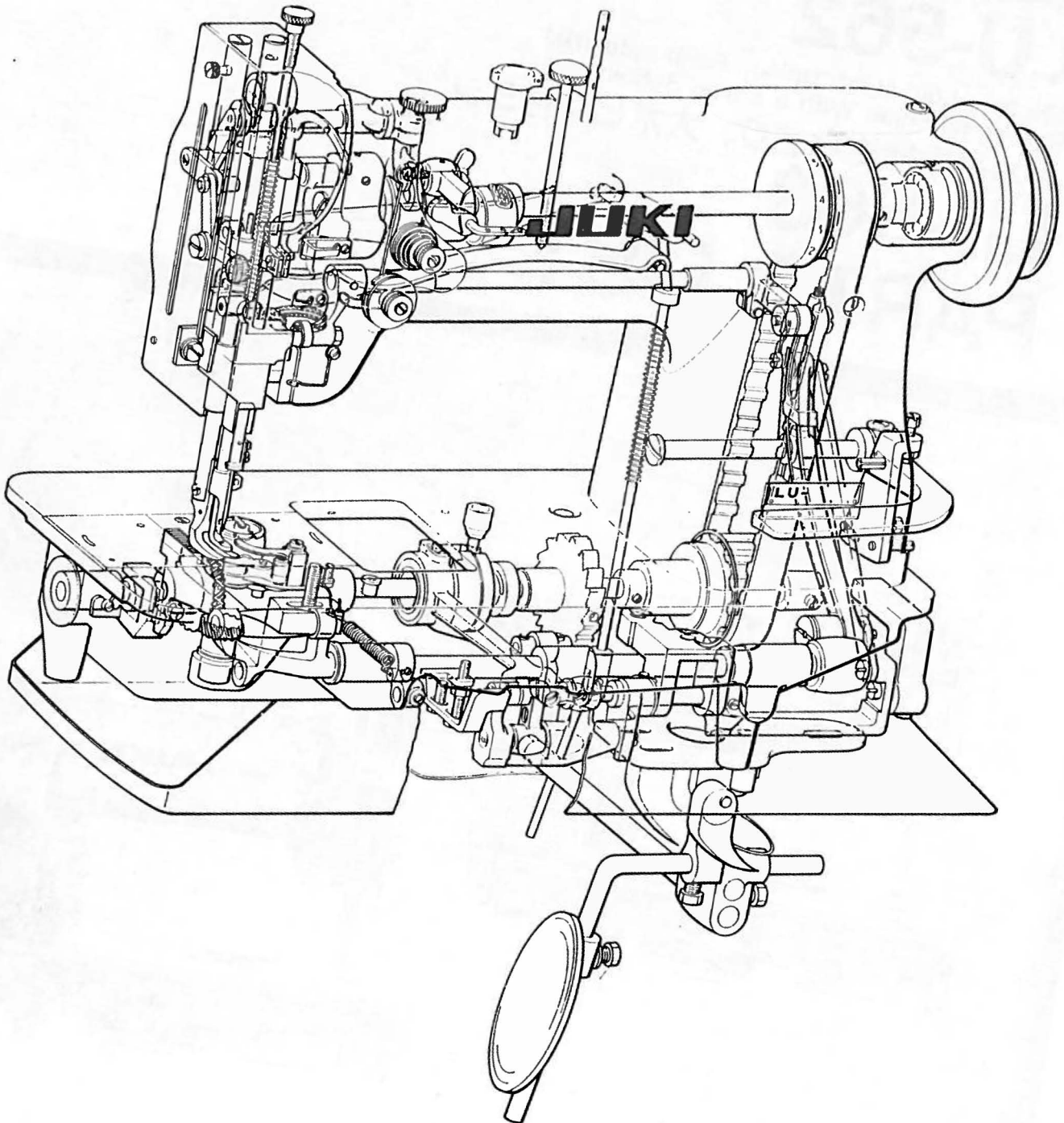

HOW TO MAKE USE OF THIS PARTS LIST

パーツリストの見方

1. The part numbers of parts shown in the figure indicate the corresponding numbers (Ref. No.) shown by the Index.
 図に示された部品の品番は、図にふられているNo (Ref No)に対応するインデックスによって、その品番がわかります。

2. Explanation of codes 記号の説明

1) Codes on the "Note" column "注記" 欄の記号

- ① ☆..... means this part is changed from the previous parts list.
 前回のパーツリストに対して今回変更された部品を意味します。
- ② #01..... refer to the "Note" explanation at bottom of page.
 #01 ページ下の "注記" の説明を参照して下さい。

2) Codes on the "E.C. (Engineering change)" column "変更年月" 欄の記号

- ① A.10/83.... Added from October, 1983
 1983年10月より追加された。
- ② D.10/83.... Obsoleted from October, 1983
 1983年10月より削除された。

③ When previous parts (Obsoleted part) and new parts (Added parts) are not interchangeable with each other:
 部品の互換性がない変更の場合

In this case, even obsoleted part (D.) can be ordered with the obsoleted part number, so select the parts with changed dates and place your orders.
 この場合は削除(D)された品番でもご注文できますから、変更年月により、いずれかの部品を選択してご注文下さい。

Example (例)

Ref. No.	Note 注記	Part No. 品番	Description	E.C. 変更年月	品名	Amt. Req. 数量
1	☆	B1401-100-000	Needle bar	D.10/83	ハリボー	-
1-1	☆	B1401-100-000-A	Needle bar	A.10/83	ハリボー	1
2	☆	B1105-200-000	Frame cover	D.10/83	B1105-300-000	-
	☆	B1105-300-000	Frame cover	A.10/83	フレームカバー	1

④ In case when previous parts and new part are interchangeable with each other:
 部品の互換性がある場合の変更

In this case the new part number is replaced on the "品名 (Japanese)" column of the previous parts, so please order by the new part number.
 この場合は、旧部品の和文品名欄にそれにかわる新しい品番が記入してありますので、新しい品番でご注文下さい。

⑤ C.10/83

1	☆	B1105-500-000	Frame cover	C.10/83	B1105-600-000	1
		↑ Correct No. 正しい品番			↑ Wrong No. 誤り品番	

Please order by the correct part number.
 正しい品番でご注文下さい。

⑥ M.10/83..... The amount required is changed from October, 1983
 The new amount required is shown in the "Amt. Req." column.
 1983年10月より数量が変更になった。この場合数量欄には新しい数量が表示してあります。

3) Codes on the "Amt. Req." column "数量" 欄の記号

- ① 2..... Indicates amount required is 2.
 数量、2個を表わします。
- ② 2.0..... Indicates length in meters. (unit is meter)
 長さ、2メートルを表わします。(単位はメートルです)
- ③ -..... Indicates parts obsoleted from the parts list.
 このパーツリストから削除された部品です。
- ④ (1)..... Indicates sub parts which construct the assembly part.
 Assembly part is shown as "asm." and クミ in Japanese, in the "Description" column.
 組部品を構成している子部品を表わします。組部品は品名欄に英文で "asm." 和文でクミと表示してあります。

When Ordering The Spare Parts:

In order to ensure that we deliver the correct parts to you, please clearly state when ordering the corresponding PART NUMBER (ex. B1109-012-A00) and also the PARTS LIST NUMBER (ex. 0010-01, given at the top right of the cover) or the MACHINE SERIAL NUMBER, because there are some parts which have been changed.

補用部品注文の際のご注意

このパーツリストに記載されている補用部品をご注文の際は、部品の番号(例えば、B1109-012-A00)でご注文下さい。合わせて、ご覧のパーツリストの管理番号(表紙右上、例えば、No0010-01)又は、機械番号をご連絡頂ければ幸いです。又、改良のため部品の一部が変更になる場合がありますのでご了承下さい。

CONTENTS

目次

1. MACHINE HEAD & MISCELLANEOUS COVER COMPONENTS	
頭部外装関係.....	1
2. UPPER MAIN SHAFT & THREAD TAKE-UP COMPONENTS	
上軸、天秤関係.....	3
3. SEWING HOOK & SHAFT COMPONENTS	
下軸、釜軸関係.....	5
4. NEEDLE BAR & WALKING FOOT COMPONENTS	
針棒、上送り関係.....	7
5. PRESSER BAR & FEED ROCK SHAFT COMPONENTS	
押エ棒、水平軸関係.....	9
6. REVERSE FEED CONTROL LEVER COMPONENTS	
送りレバー関係.....	11
7. SAFETY CLUTCH MECHANISM, KNEE LIFTER COMPONENTS	
安全装置、膝上げ関係.....	13
8. SUBCLASS COMPONENTS	
サブクラス関係.....	15
(1) LU-562A.....	15
(2) LU-562-3.....	15
(3) LU-563-3.....	15
9. BELT COVER COMPONENTS (SPECIAL ORDER PARTS)	
ベルトカバー関係 (特別注文部品).....	16
10. NUMERICAL INDEX OF PARTS	
索引.....	17

1. MACHINE HEAD & MISCELLANEOUS COVER COMPONENTS

頭部外装関係

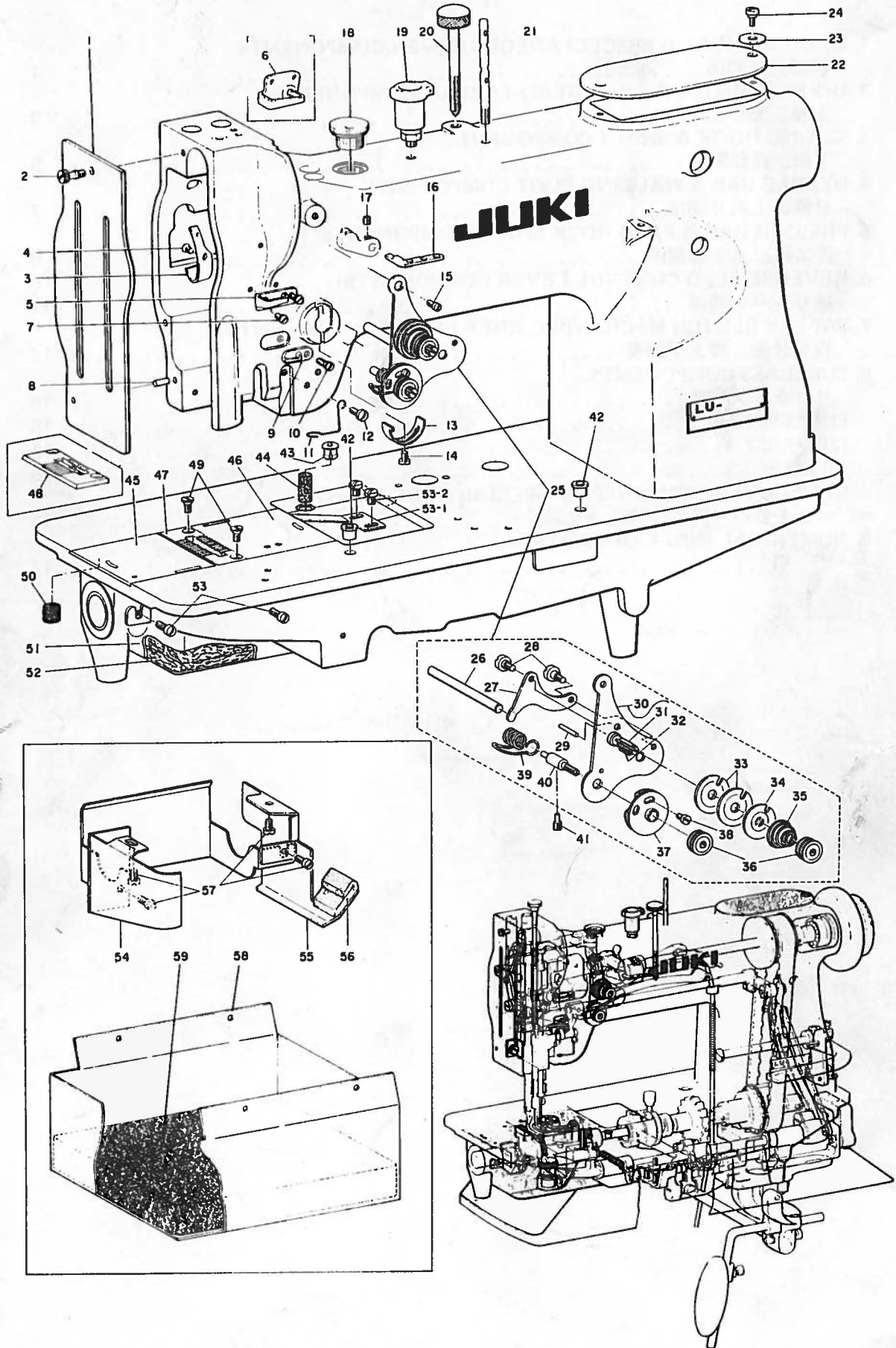

1. MACHINE HEAD & MISCELLANEOUS COVER COMPONENTS

頭部外装関係

Ref. No.	Note	Part No.	Description	E. C.	品名	Amt. Req.
	注記	品番		変更年月		数量
1		B3101-053-000	Face plate		メンイタ	1
2		B3106-019-000	Screw	D.8/83	SS-7090610-SP	-
		SS-7090610-SP	Screw 9/64-40 L=6	A.8/83	マルヒラネジ 9/64-40 L=6	1
3		B1140-051-000	Take-up oil splasher		テンビン ユポーイタ	1
4		SS-3090610-SP	Screw 9/64-40 L=6.0		マルネジ 9/64-40 L=6	1
5	01	B1129-051-000	Frame thread guide, upper		イトアンナイ ウエ	1
6	02	B1129-563-000	Frame thread guide, upper		イトアンナイ ウエ	1
7		SS-2090710-SP	Screw 9/64-40 L=7.0		マルサラネジ 9/64-40 L=7	2
8		B1103-051-000	Face plate pin		メンイタ トメピン	1
9		B1130-051-000	Frame thread guide, middle		イトアンナイ ナカ	1
10		SS-2090710-SP	Screw 9/64-40 L=7.0		マルサラネジ 9/64-40 L=7	1
11		B1131-562-000	Frame thread guide, lower		イトアンナイ シタ	1
12		SS-3090610-SP	Screw 9/64-40 L=6.0		マルネジ 9/64-40 L=6	1
13		B3138-051-000	Take-up spring adjusting plate	D.4/78	B3138-512-000	-
		B3138-512-000	Take up spring adjusting plate	A.4/78	イトトリバネ チョーセツイタ	1
14		SS-7090520-SP	Screw 9/64-40 L=4.5		マルヒラネジ 9/64-40 L=4.5	1
15		SS-7110720-SP	Screw 11/64-40 L=7.0		マルヒラネジ 11/64-40 L=7	1
16		B1128-051-000	Three-hole thread eyelet	D.8/79	B1128-522-000	1
		B1128-522-000	Three-hole thread eyelet	A.8/79	ミツメイトカケ	1
17		SS-8110510-SP	Screw 11/64-40 L=5.0		トメネジ 11/64-40 L=5	1
18		B3501-051-000	Oil filter sleeve		メタル アブラ チューニュー ツツ	1
19		B1155-053-000	Oil cup		ウウオクリ ロッド オイルカップ	1
20		B1509-051-000	Adjusting screw		オサエ チョーセツネジ	1
21		B1114-051-000	Needle thread guide pin		イトアンナイボー	1
22		B1150-051-000	Top cover		テンイタ	1
23		B1152-051-000	Washer		テンイタ ネジザガネ	1
24		SD-0630241-SD	Hinge screw D=6.30 H=2.4		ダンネジ D=6.30 H=2.4	1
25		B3121-053-0A0	Tension controller base asm.		イトチョーシ ダイイタ クミ	1
26		B3122-053-000	Tension release bar		イトユルメ オシボー	(1)
27		B3134-051-000	Tension release lever		イトユルメ ウケイタ	(1)
28		SD-0470281-SP	Hinge screw D=4.80 H=2.3		ダンネジ D=4.80 H=2.3	(2)
29		B3127-051-000	Tension release pin, short		イトユルメ ピン	(1)
30		B3124-051-0A0	Tension stud asm.		イトチョーシボー クミ	(1)
31		B3124-051-000	Tension stud		イトチョーシボー	(1)
32		B3131-051-000	Thread tension disc pin		イトチョーシ サラ トメピン	(1)
33		B3126-051-000	Tension disc		イトチョーシ サラ	(2)
34		B3132-051-000	Tension disc holder		イトチョーシサラ オサエ	(1)
35		B3129-053-000	Tension spring		イトチョーシバネ	(1)
36		B3125-012-000	Thread tension stud nut		イトチョーシ ナット	(2)
37		B3137-051-0A0	Take-up spring guide disc asm.		イトトリバネ アンナイザラ クミ	(1)
38		SS-4080610-SP	Screw 1/8-44 L=6.4		ナベネジ 1/8-44 L=6.4	(1)
39		B3128-051-000	Thread take-up spring		イトトリバネ	(1)
40		B3123-051-000	Take-up spring stud		イトトリ バネジク	(1)
41		SS-8111251-SP	Screw 11/64-40 L=12.0		トメネジ 11/64-40 L=12	1
42		B1157-009-0A0	Oil cup asm.	D.8/79	シタジク オイルカップ クミ	-
43		B1405-012-000	Cap		キャップ	1
44		B1132-562-000	Oil felt		キューユ フェルト	1
45		B1112-053-000-A	Bed slide, left		スベリイタ ヒダリ	1
46		B1113-053-000-A	Bed slide, right		スベリイタ ミギ	1
47	01	B1109-562-000	Throat plate		ハリイタ	1
48	02	B1109-053-000-A	Throat plate		ハリイタ	1
49		SS-2110920-TP	Screw 11/64-40 L=8.5		マルサラネジ 11/64-40 L=8.5	2
50		B3542-581-000	Oil felt		フェルト	1
51	01	B1839-053-000	Oil receiving cover	D.7/79	カマジクダイ カバー	-
52	01	B1841-053-000	Oil drip felt	D.7/79	カマジクダイ アブラウケ	-
53	01	SS-7110410-SP	Screw 11/64-40 L=4.0	D.7/77	SS-7110510-SP	-
	01	SS-7110510-SP	Screw 11/64-40 L=5.0	A.7/77	マルヒラネジ 11/64-40 L=5	2
53-1		B1111-563-000	Bed slide spring	A.4/78	スベリイタ バネ	1
53-2		SS-7110510-SP	Screw 11/64-40 L=5.0	A.4/78	マルヒラネジ 11/64-40 L=5	2
54	02	B1838-563-000	Oil shield, (A)		カマジクダイ ユポーイタ A	1
55	02	B1844-563-000	Oil shield, (B)		カマジクダイ ユポーイタ B	1
56	02	B8146-563-000	Oil drip felt		ユポーバン アブラウケ	1
57	02	SS-7110510-SP	Screw 11/64-40 L=5.0		マルヒラネジ 11/64-40 L=5	4
58	02	B1839-563-000	Oil receiving cover		カマジクダイ アブラダメ	1
59	02	B1841-563-000	Oil drip felt		カマジクダイ アブラウケ	1

Note (注記) 01 For LU-562 LU-562用
 02 For LU-563 LU-563用

2. UPPER MAIN SHAFT & THREAD TAKE-UP COMPONENTS

上軸、天秤關係

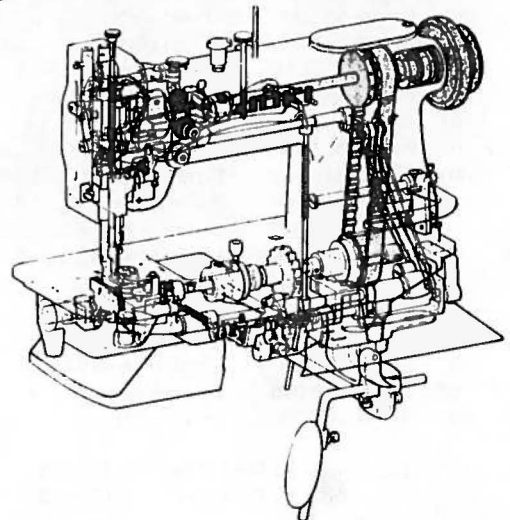
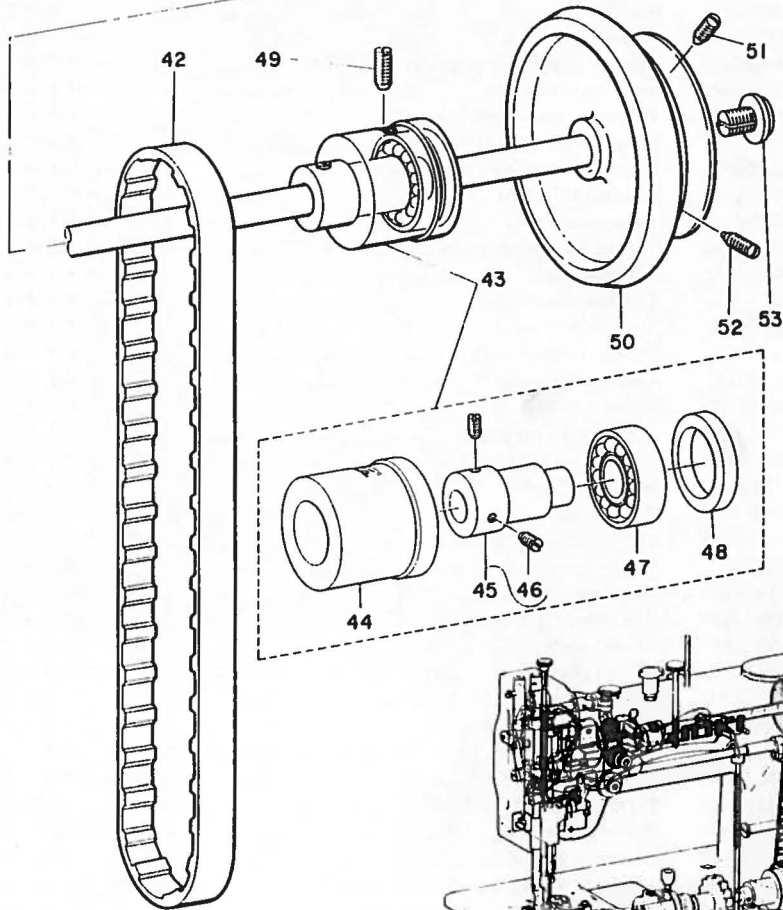
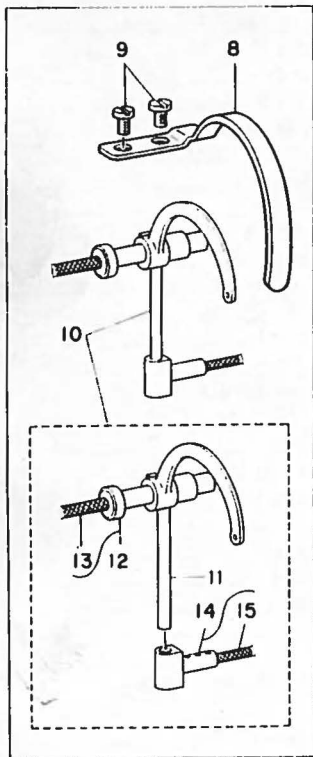
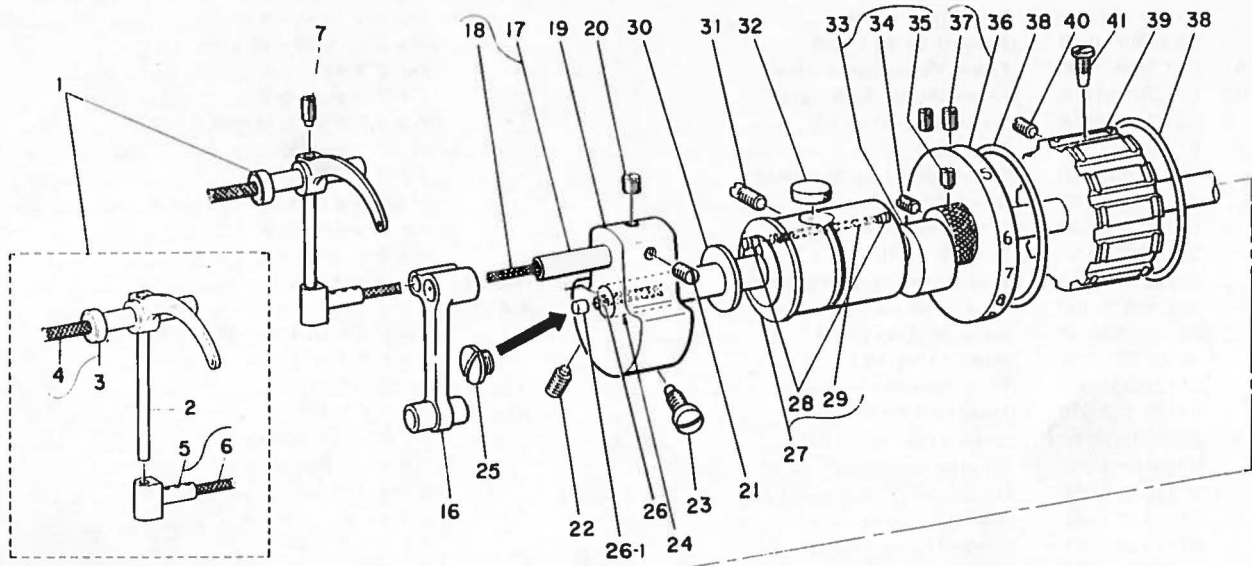

2. UPPER MAIN SHAFT & THREAD TAKE-UP COMPONENTS

上軸、天秤関係

Ref. No.	Note	Part No.	Description	E.C.	Amt. Req.
	注記	品番		変更年月	数量
1	◇01	B1905-053-0B0	Thread take-up lever asm.		1
2	◇01	B1905-053-000	Thread take-up lever		(1)
3	◇01	B1906-051-0A0	Take-up lever pin asm.		(1)
4	◇01	CQ-2020000-00	Oil wick		(0.1)
5	◇01	B1907-051-0A0	Take-up lever thrust pin asm.		(1)
6	◇01	CQ-2020000-00	Oil wick		(0.1)
7		SS-8151150-SP	Screw 15/64-28 L=10.5		1
8	◇02	B1158-563-000	Thread take-up lever cover		1
9	◇02	SS-7150940-SP	Screw 15/64-28 L=9.0	D.2/79	-
	◇02	SS-7150740-SP	Screw 15/64-28 L=7.0	A.2/79	1
10	◇02	B1905-563-0B0	Thread take-up lever asm.		1
11	◇02	B1905-563-000	Thread take-up lever		(1)
12	◇02	B1906-051-0A0	Take-up lever pin asm.		(1)
13	◇02	CQ-2020000-00	Oil wick		(0.1)
14	◇02	B1907-051-0A0	Take-up lever thrust pin asm.		(1)
15	◇02	CQ-2020000-00	Oil wick		(0.1)
16		B1408-051-000	Needle bar crank rod		1
17		B1210-051-0A0	Needle bar crank pin asm.		1
18		CQ-2020000-00	Oil wick		(0.1)
19		B1206-051-000	Counterweight		1
20		SS-8680540-SP	Screw 9/32-28 L=4.5		1
21		SS-8680730-SP	Screw 9/32-28 L=7.0		1
22		SS-8681650-TP	Screw 9/32-28 L=16.0		1
23		SS-7681750-TP	Screw 9/32-28 L=16.5		1
24		D1201-055-800	Main shaft		1
25		B1207-051-0A0	Main shaft plug screw asm.	D.8/79	-
26		CQ-2020000-00	Oil wick		0.1
26-1		TA-0570601-M0	Oil plug	A.8/79	1
27		B1202-051-0A0	Main shaft bushing, front asm.		1
28		B1230-051-000	Oil plug	M.8/78	(2)
29		CQ-2020000-00	Oil wick		(0.1)
30		B1205-051-000	Thrust washer	D.3/79	-
31		SS-8151350-SP	Screw 15/64-28 L=13.0		1
32		B1203-051-000	Oil felt		1
33		D1450-055-BA0	Feed eccentric asm.		1
34		SS-8660530-TP	Screw 1/4-40 L=4.5		(1)
35		SS-8660970-TP	Screw 1/4-40 L=8.5		(1)
36		B1220-562-0A0	Stitch graduator asm.		1
37		SS-8151230-SP	Screw 15/64-28 L=12.0		(2)
38		B1214-019-000	Sprocket ring		2
39		B1302-051-000	Sprocket wheel, upper		1
40		SS-8681650-TP	Screw 9/32-28 L=16.0		1
41		SS-7681750-TP	Screw 9/32-28 L=16.5		1
42		B1301-051-000	Timing belt		1
43		B1216-051-0A0	Main shaft bushing(1), rear asm.		1
44		B1216-051-000	Main shaft bushing(1), rear		(1)
45		B1217-051-0A0	Main shaft bushing(2), rear asm.		(1)
46		SS-8150710-SP	Screw 15/64-28 L=7.0		(2)
47		B1219-051-000	Bearing	D.8/79	-
		SB-1150002-00	Bearing	A.8/79	(1)
48		B1218-051-000	Rear bearing retaining collar		(1)
49		SS-8151350-SP	Screw 15/64-28 L=13.0		1
50		B1227-053-000	Hand wheel		1
51		SS-8152030-SP	Screw 15/64-28 L=20.0		1
52		SS-8151780-SP	Screw 15/64-28 L=17.0		1
53		B1233-012-000	End screw		1

Note (注記) ◇01 For LU-562 LU-562用
 ◇02 For LU-563 LU-563用

3. SEWING HOOK & SHAFT COMPONENTS

下軸、釜軸関係

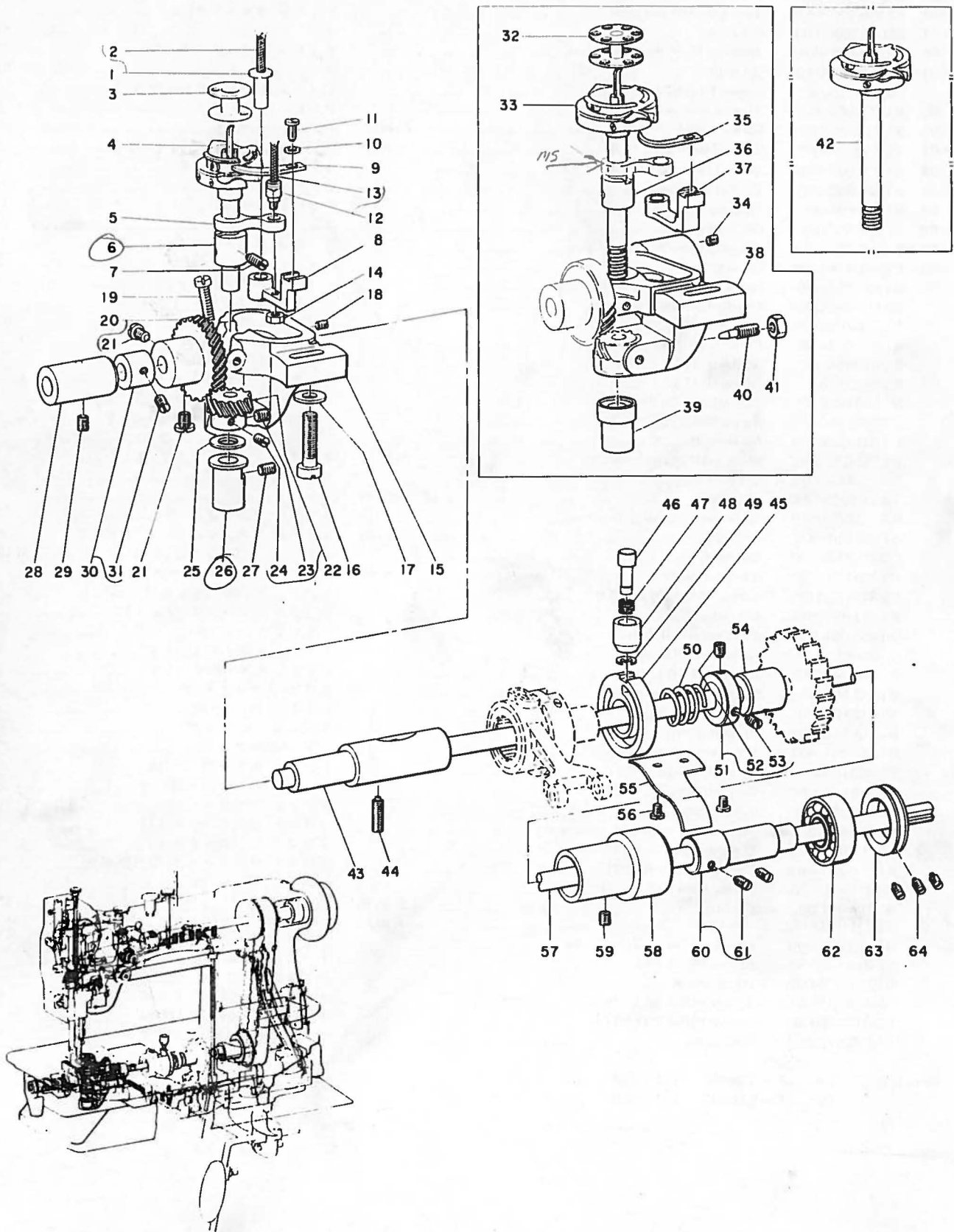

3. SEWING HOOK & SHAFT COMPONENTS

下軸、釜軸関係

Ref. No.	Note	Part No.	Description	E.C.	Amt. Req.
	注記	品番		変更年月	数量
1		B1823-051-0A0	Bobbin case opening lever crank pin asm.		1
2		CQ-2020000-00	Oil wick		(0.1)
3	001	B9117-051-000	Bobbin		1
4	001	B1830-055-0A0	Vertical-axis sewing hook asm.		1
5		B1820-051-000	Bobbin case opening lever link		1
6	001	B1814-051-000	Hook driving shaft bushing, upper		1
7		SS-8151150-SP	Screw 15/64-28 L=10.5		1
8	001	B1822-051-000	Bobbin case opening lever crank		1
9	001	B1824-051-000	Bobbin case opening lever		1
10		WP-0371016-SD	Washer 3.7 x 8.0 x 1.0		1
11		SS-6090620-SP	Screw 9/64-40 L=6.0		1
12		B1821-051-0A0	Crank screw stud asm.		1
13		CQ-2020000-00	Oil wick		(0.1)
14		NS-6110420-SP	Nut 11/64-40		1
15	001	B1811-051-000	Hook shaft saddle, right		1
16		SS-7762840-SP	Screw 1/4-28 L=28.0		1
17		B1812-051-000	Washer	D.1/76	—
		WP-0753016-SZ	Washer 7.5 x 16.0 x 3.0	A.1/76	1
18	001	SS-8150710-SP	Screw 15/64-28 L=7.0		1
19		SS-6153040-SP	Screw 15/64-28 L=30.0		1
20		B1816-521-0A0	Hook shaft gear, large asm.	C.8/78	1
21		B1831-055-000	Screw	D.3/76	—
		SS-8660830-TP	Screw 1/4-40 L=8.3	A.3/76	(2)
22		B1817-051-0A0	Hook shaft gear, small asm.	C.11/77	1
23		SS-8660530-TP	Screw 1/4-40 L=4.5		(1)
24		SS-8660670-SP	Screw 1/4-40 L=6.1		(1)
25		B1818-051-800	Thrust washer		1
26	001	B1815-051-000	Hook driving shaft bushing, lower		1
27		SS-8150710-SP	Screw 15/64-28 L=7.0		1
28		B1802-053-000	Hook driving shaft bushing, front		1
29		SS-8152030-SP	Screw 15/64-28 L=20.0		1
30		B1840-051-0A0	Feed driving eccentric asm.		1
31		SS-8150580-SP	Screw 15/64-28 L=5.0		(1)
32	002	B9117-563-000	Bobbin		1
33	002	B1830-563-0A0	Vertical-axis sewing hook asm.		1
34	002	SS-8151230-SP	Screw 15/64-28 L=12.0		1
35	002	B1824-563-000	Bobbin case opening lever		1
36	002	B1814-563-000	Hook driving shaft bushing, upper		1
37	002	B1822-563-000	Bobbin case opening lever crank		1
38	002	B1811-563-000	Hook driving shaft saddle		1
39	002	B1815-563-000	Hook driving shaft bushing, lower		1
40	002	B1843-563-000	Oil adjusting screw		1
41	002	NS-6110420-SP	Nut 11/64-40		1
42	003	B1830-563-BA0	Hook asm., for extreme thick thread		1
43		B1804-051-000	Hook driving shaft bushing, intermediate		1
44		SS-8151550-SP	Screw 15/64-28 L=15.0		1
45		B1626-562-000	Feed eccentric guide		1
46		B1636-055-000	Feed eccentric adjusting knob		1
47		B1639-051-000	Spring		1
48		B1637-055-000	Sleeve	D.3/76	—
49		RE-0500000-K0	Snap ring 5.0		1
50		B1624-055-000	Feed eccentric body spring		1
51		B1625-057-0A0	Retaining collar asm.		1
52		SS-8110510-SP	Screw 11/64-40 L=5.0		(1)
53		SS-8110750-SP	Screw 11/64-40 L=6.5		(1)
54		B1807-512-000	Bushing (B), intermediate		1
55		B1806-051-000	Hook driving shaft timing indicator	D.1/77	—
56		SS-7090520-SP	Screw 9/64-40 L=4.5	D.1/77	—
57		B1801-562-000	Hook driving shaft		1
58		B1807-051-000	Hook driving shaft bushing(1), rear		1
59		SS-8152030-SP	Screw 15/64-28 L=20.0		1
60		B1808-051-0A0	Hook driving shaft bushing(2), rear asm.		1
61		SS-8150750-SP	Screw 15/64-28 L=7.0		(2)
62		B1219-051-000	Bearing	D.8/79	—
		SB-1150002-00	Bearing	A.8/79	1
63		B1809-051-000	Bearing retaining collar		1
64		SS-8090530-TP	Screw 9/64-40 L=5.0		3

Note (注記) 001 ... For LU-562 LU-562用
 002 ... For LU-563 LU-563用
 003 ... Special order part for LU563 (For extremely thick thread) LU-563用特別注文部品 (極太糸用)

4. NEEDLE BAR & WALKING FOOT COMPONENTS

針棒、上送り関係

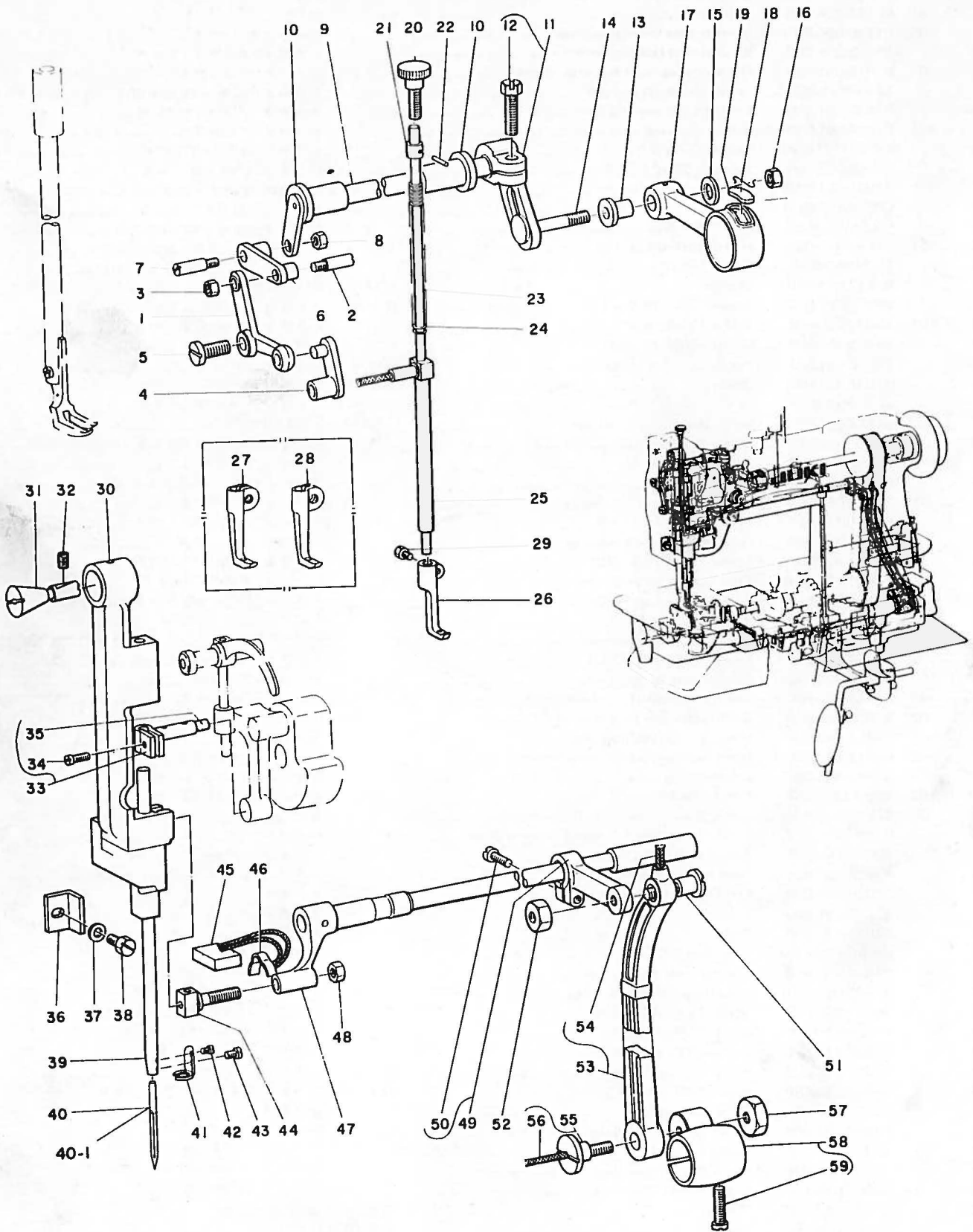

4. NEEDLE BAR & WALKING FOOT COMPONENTS

針棒、上送り関係

Ref. No.	Note	Part No.	Description	E.C.	Amt. Req.
	注記	品番		変更年月	数量
1		B1459-053-00A	L shaped link		1
2		B1459-053-00B	L shaped link connecting screw stud		1
3		NS-6110310-SP	Nut 11/64-40		1
4		B1465-053-000	Walking bar driving link		1
5		SS-6111140-SP	Screw 11/64-40 L=11.0		1
6		B1458-053-000	Connecting link		1
7		B1457-055-000	Screw stud		1
8		NS-6660430-SP	Nut 1/4-40		1
9		B1456-053-000	Upper feed driving shaft		1
10		B1455-053-000	Bushing		2
11		D1454-055-BA0	Upper feed spring rod asm.		1
12		SS-7161640-SP	Screw 1/4-24 L=16.0	D.5/81	-
		SS-9161610-SP	Screw 1/4-24 L=16.0	A.5/81	(1)
13		D1455-055-B00	Connecting stud		1
14		D1456-055-B00	Hinge screw		1
15		D1457-055-B00	Washer		1
16		D1458-055-B00	Wing screw	D.4/79	-
		NS-6110530-SP	Nut 11/64-40		1
17		D1453-055-B00	Upper feed driving rod		1
18		B1213-012-000	Felt retainer		1
19		B1702-012-000	Oil felt		1
20		B1469-053-000	Adjusting thumb screw		1
21		B1467-053-008	Retaining collar		1
22		B1467-053-00C	Retaining collar pin	D.1/78	-
		B1467-521-00C	Retaining collar pin	A.1/78	1
23		B1467-053-00A	Spring pole		1
24		B1468-053-000	Walking bar spring		1
25		B1466-053-000	Walking bar	D.1/77	1
		B1466-053-000-A	Walking bar	A.1/77	1
26		B1470-053-000	Walking foot		1
27	004	B1470-562-B00	Walking foot		1
28	005	B1470-053-C00	Walking foot (C)	A.3/76	1
29		SS-6110710-TP	Screw 11/64-40 L=6.5		1
30		B1420-053-000	Needle bar frame		1
31		B1421-051-000	Needle bar frame taper stud		1
32		SS-8151160-SP	Screw 15/64-28 L=11.0		1
33		B1411-053-0B0	Needle bar connection asm.		1
34		SS-7090910-SP	Screw 9/64-40 L=8.5		(1)
35		B1412-051-000	Felt		(1)
36		B1423-051-000	Needle bar frame guide		1
37		WP-0480856-SP	Washer 4.8 x 8.4 x 0.8		1
38		SS-9111010-SP	Screw 11/64-40 L=9.5		1
39		B1401-053-000	Needle bar		1
40		MDi-300B2300	Needle D1 x 3 #23		1
40-1	008	MC-3515016-00	Schmetz needle 332 #160	A.10/81	1
41		B1419-053-000	Needle bar thread guide		1
42	*	SS-7060310-SP	Screw 3/32-56 L=3.0	D.4/84	-
43		SS-7080510-SP	Screw 1/8-44 L=4.5	D.9/80	-
		SS-7080510-TP	Screw 1/8-44 L=4.5	A.9/80	1
44		B1425-051-0A0	Needle bar frame slide block		1
45		B1438-051-0A0	Oil wick asm.		1
46		B1437-051-000	Oil wick retainer		1
47		B1429-051-0A0	Needle bar frame rock shaft asm.		1
48		NS-6620310-SP	Nut 3/16-32		1
49		B1431-051-0A0	Needle bar shaft rear crank asm.		1
50		SS-6151440-SP	Screw 15/64-28 L=14.0		(1)
51		SD-0790801-SP	Hinge screw D=7.94 H=8.0		1
52		NS-6160520-SP	Nut 1/4-24		1
53		B1434-051-0A0	Needle bar frame driving rod asm.		1
54		CQ-2020000-00	Oil wick		(0.1)
55		SD-095080A-SP	Hinge screw asm.		1
56		CQ-2020000-00	Oil wick		(0.1)
57		NS-6700420-SP	Nut 5/16-24		1
58		B1435-051-0A0	Driving rod crank asm.		1
59		SS-6151920-SP	Screw 15/64-28 L=19.0		(1)

Note (注記) 004 Special order part for LU-562, LU-563 (With teeth) LU-562、LU-563特別注文部品 (歯付)
 005 Special order part for LU-562, LU-563 (For light weight materials) LU-562、LU-563特別注文部品 (薄物用)
 008 Special order part (For JE) 特別注文部品 (JE用)

5. PRESSER BAR & FEED ROCK SHAFT COMPONENTS

押工棒、水平軸関係

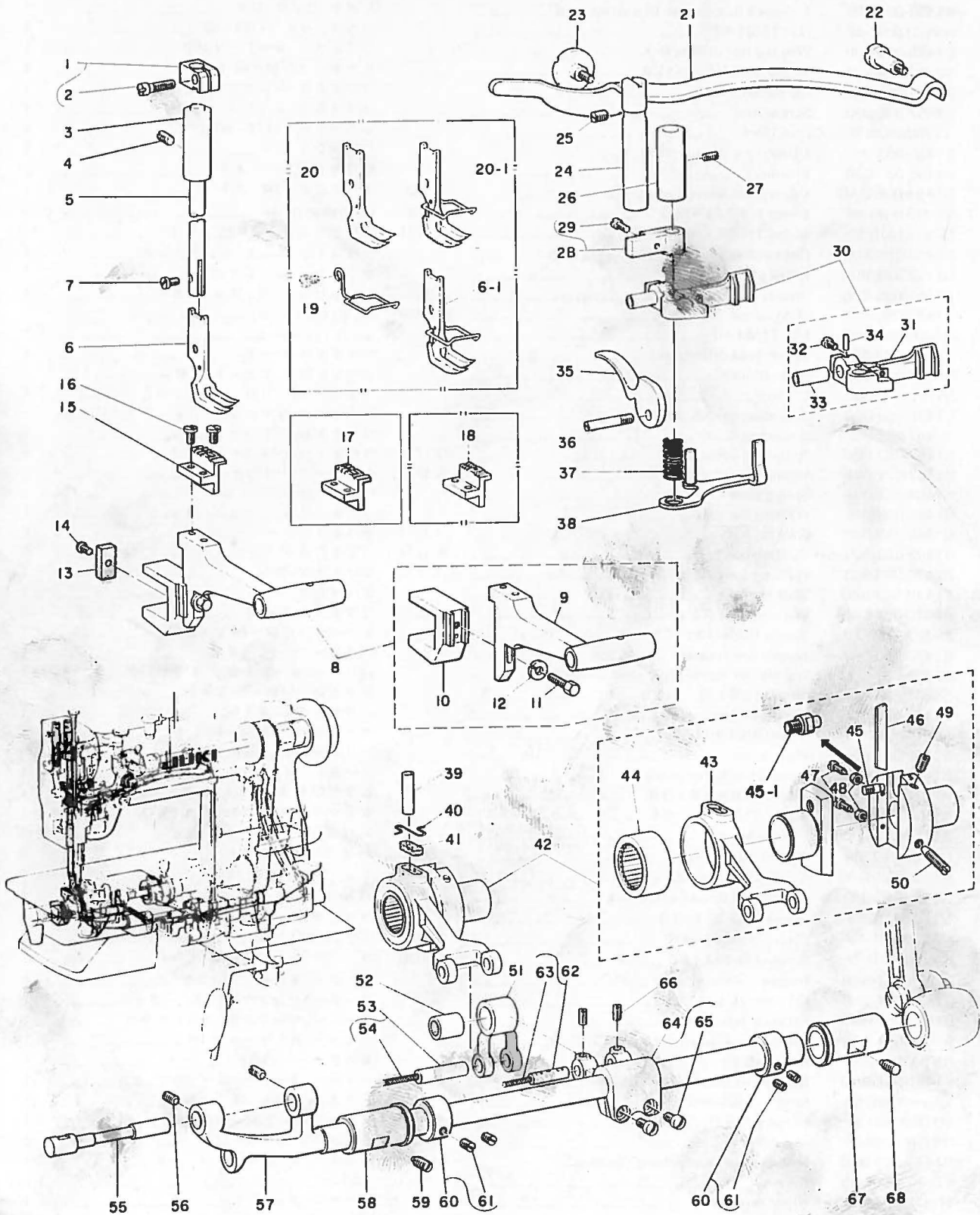

5. PRESSER BAR & FEED ROCK SHAFT COMPONENTS

押工棒、水平軸関係

Ref No.	Note	Part No.	Description	E.C.	品名	Amt. Req.
	注記	品番		変更年月		数量
1		B1507 051 0A0	Presser bar guide bracket	D.8/79	B1507-562-0A0	-
		B1507 562 0A0	Presser bar guide bracket	A.8/79	オサエボーダキ クミ	1
2		SS-7090910-SP	Screw 9/64-40 L=8.5	D.8/79	SS-7091310-SP	-
		SS-7091310-SP	Screw 9/64-40 L=13	A.8/79	マルヒラネジ 9/64-40 L=13	(11)
3		B1503-051-B00	Presser bar bushing, lower		オサエボー シタメタル 2	1
4		SS-8151150-SP	Screw 15/64-28 L=10.5		トメネジ 15/64-28 L=10.5	1
5		B1501-040-000	Presser bar		オサエボー	1
6		B1525-053-000	Presser foot		オサエ アシ	1
6-1	06	B1525-053-0A0	Presser foot asm.	A.4/76	オサエアシ クミ	1
7		SS-6090910-TP	Screw 9/64-40 L=9.0		ヒラネジ 9/64-40 L=9	1
8		B1602-055-0A0	Feed bar asm.		オクリダイ クミ	1
9		B1602-055-000	Feed bar		オクリダイ	(11)
10		B1604-051-000	Feed bar slide fork		オクリダイ フタマタ	(1)
11		SS-9151440-CP	Screw		6 カクボルト 15/64-28 L=14	(1)
12		WS-0651510-KP	Spring washer 6.5 x 12.5 x 1.5		バネザガネ 6.5x12.5x1.5	(11)
13		B1605-051-000	Oil supply felt		オクリダイ フタマタ アブラダメフェルト	1
14		SS-5080710-SP	Screw 1/8-44 L=6.5		トラスネジ 1/8-44 L=6.5	1
15	001	B1613-053-000	Feed dog	D.3/79	B1613-563-000	-
	001	B1613-563-000	Feed dog	A.3/79	オクリバ	1
16		B1611-055-000	Screw		オクリトメネジ	2
17	002	B1613-563-000	Feed dog		オクリバ	1
18	007	B1613-563-B00	Feed dog		オクリバ	1
19	006	B1471-562-000	Needle guard		ハリボー アンゼンカバー	1
20	004	B1525-562-B00	Presser foot		オサエ アシ	1
20-1	006	B1525-562-BA0	Presser foot asm.	A.4/76	オサエアシ クミ	1
21		B1505-053-000	Adjusting plate spring		オサエ チョーセツ イタバネ	1
22		SD-0801601-SP	Hinge screw D=8.00 H=16.0		ダンネジ D=8 H=16	1
23		SD-0800481-SP	Hinge screw D=8.00 H=4.9		ダンネジ D=8 H=4.9	1
24		B1502-051-000	Presser bar guide sleeve		オサエボー アンナイツツ	1
25		SS-8151150-SP	Screw 15/64-28 L=10.5		トメネジ 15/64-28 L=10.5	1
26		B1503-051-A00	Presser bar bushing, upper		オサエボー ウワメタル 1	1
27		SS-8151150-SP	Screw 15/64-28 L=10.5		トメネジ 15/64-28 L=10.5	1
28		B1504-051-0A0	Presser bar connection asm.		オサエボーダキ アンナイ クミ	1
29		SS-7090910-SP	Screw 9/64-40 L=8.5		マルヒラネジ 9/64-40 L=8.5	(1)
30		B1460-053-0A0	Hand lifter mounting bracket asm.		オサエアゲテコダイ クミ	1
31		B1460-053-00A	Hand lifter mounting bracket		オサエアゲ テコダイ	(1)
32		SS-7111310-SP	Screw 11/64-40 L=12.8		マルヒラネジ 11/64-40 L=12.8	(1)
33		B1460-053-00B	Connecting pin		オサエアゲ テコダイ ジク	(1)
34		PT-0201200-S0	Pin 2.0 x 12		テーパピン 2.0x12	(1)
35		B1512-051-000	Hand lifter		オサエアゲ	1
36		B1515-051-000	Hand lifter pin		オサエアゲ ジク	1
37		B1462-053-000	Thread release spring		イトユルメ ウケイタ バネ	1
38		B1461-053-0A0	Thread release guide asm.		イトユルメ ウケイタ クミ	1
39		B1158-562-000	Crank connecting rod oil pipe		オクリロッド キューユ バイブ	1
40		B1213-012-000	Felt retainer		フタマタサヤ フェルト オサエ	1
41		B1702-012-000	Oil felt		ジョーゲ オクリロッド フェルト	1
42		B1614-562-0B0	Crank connecting rod asm.		オクリロッド クミ	1
43		B1614-562-000	Crank connecting rod	D.1/77	オクリロッド	-
44		B1627-562-000	Needle bearing	D.1/77	オクリロッド ニードル ベアリング	-
45		B1623-057-000	Feed adjusting screw	D.9/80	オクリ チョーセツ リードカム ピン	-
45-1		B1623-563-000	Feed adjusting screw	A.9/80	オクリチョーセツ リードカム ピン	(1)
46		B1622-057-000	Friction plate		オクリ チョーセツ カミソリ	(1)
47		B1642-057-000	Screw	D.1/76	SS-8081050-TH	-
		SS-8081050-TH	Screw 1/8-44 L=10	D.10/77	SS-8081210-TH	-
		SS-8081210-TH	Screw 1/8-44 L=11.5	D.2/82	SS-6081220-TP	-
		SS-6081220-TP	Screw 1/8-44 L=12	A.2/82	ヒラネジ 1/8-44 L=12	(2)
48		NS-6080210-SP	Nut 1/8-44		6 カクナット 1/8-44	(2)
49		SS-8151780-SP	Screw 15/64-28 L=17.0		トメネジ 15/64-28 L=17	(1)
50		SS-8151770-SP	Screw 15/64-28 L=17.0		トメネジ 15/64-28 L=17	(1)
51		B1647-562-000	Feed regulating fork link		オクリチョーセツ フタマタリンク	1
52		B1664-562-000	Needle bearing		フタマタリンク ニードル ジクウケ	1
53		B1646-562-0A0	Feed regulating link pin asm.		オクリ チョーセツリンク ジク クミ	1
54		CQ-2020000-00	Oil wick		ユシン	(0.2)
55		B1603-051-000	Feed bar shaft		オクリダイ ジク	1
56		SS-8110510-SP	Screw 11/64-40 L=5.0		トメネジ 11/64-40 L=5	2
57		B1601-562-000	Feed rock shaft		スイヘイ オクリジク	1
58		B1607-051-000	Feed rock shaft bushing, front		スイヘイ オクリジク マエメタル	1
59	*	SS-8151150-SP	Screw 15/64-28 L=10.5	D.11/84	SS-8150710-SP	-
	*	SS-8150710-SP	Screw 15/64-28 L=7	A.11/84	トメネジ 15/64-28 L=7	1
60		CS-1401010-SC	Thrust collar asm. D=14.0 W=10		スラストウケ D=14.0 W=10 クミ	2
61		SS-8150410-SP	Screw 15/64-28 L=4.0		トメネジ 15/64-28 L=4	(4)
62		B1648-562-0A0	Connecting pin asm.		スイヘイ オクリウデ ジク クミ	1
63		CQ-2020000-00	Oil wick		ユシン	(0.1)
64		B1616-562-0A0	Feed rock shaft crank asm.		スイヘイ オクリウデ クミ	1
65		SS-7111410-SP	Screw 11/64-40 L=14.0		マルヒラネジ 11/64-40 L=14	(2)
66		SS-8110520-TP	Screw 11/64-40 L=4.5		トメネジ 11/64-40 L=4.5	2
67		B1609-051-000	Feed rock shaft bushing, rear		スイヘイ オクリジク ウシロメタル	1
68		SS-8152030-SP	Screw 15/64-28 L=20.0		トメネジ 15/64-28 L=20	1

Note (注記) 01 For LU-562 LU-562用
 02 For LU-563 LU-563用
 04 Special order part for LU-562, LU-563 (With teeth) LU-562、LU-563用特別注文部品 (歯付)
 06 Special order part for LU-562, LU-563 LU-562、LU-563用特別注文部品
 07 Special order part for LU-563 (For light weight materials) LU-563用特別注文部品 (薄物用)

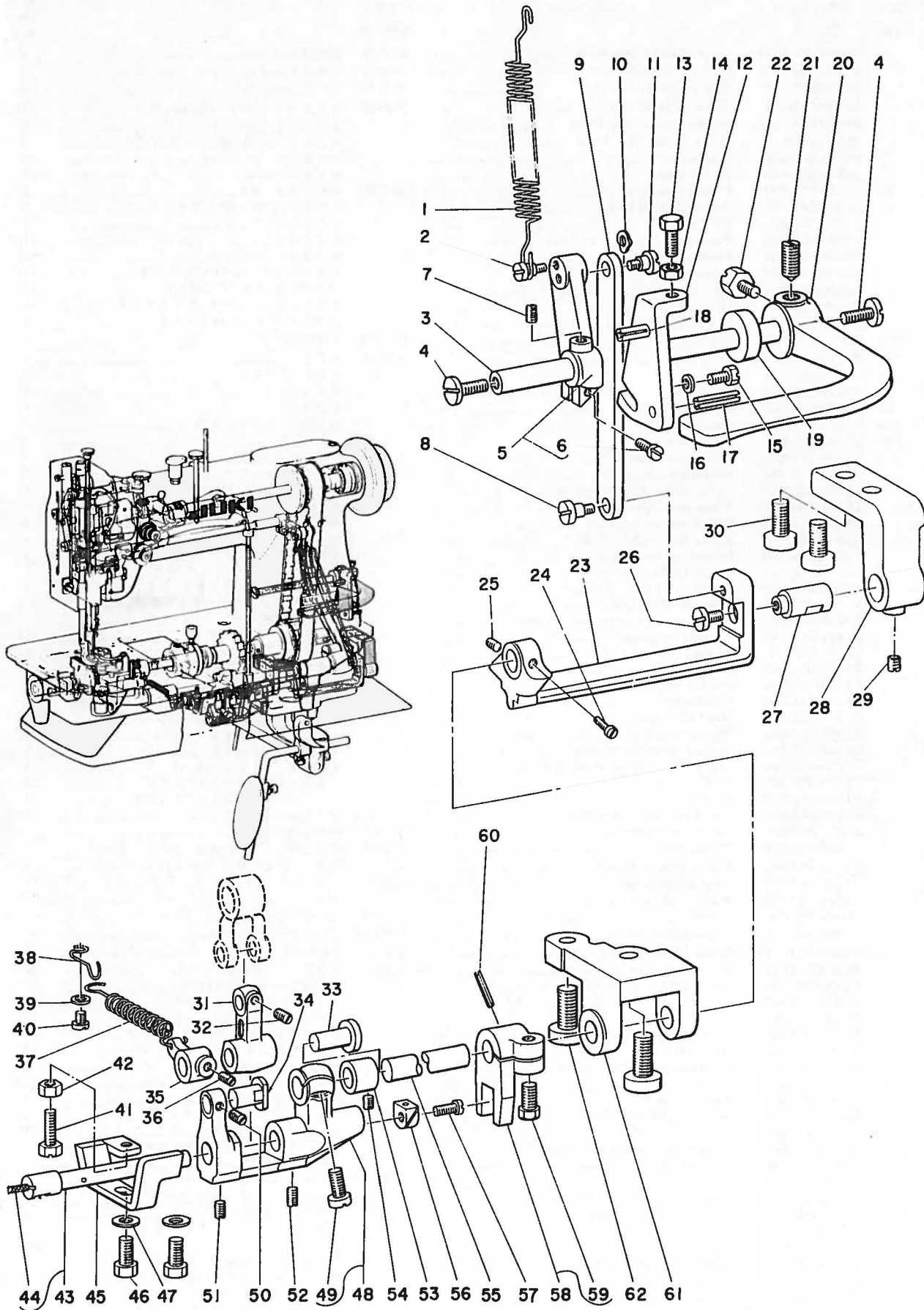

6. REVERSE FEED CONTROL LEVER COMPONENTS

送りレバー関係

Ref. No.	Note	Part No.	Description	E.C.	Amt. Req.
	注記	品番		変更年月	数量
1		B1666-562-000	Tension spring (B)		1
2		SD-0400201-SD	Hinge screw D=4.00 H=2.0		1
3		B1660-562-000	Reverse feed control lever shaft		1
4		SS-7620750-SP	Screw 3/16-32 L=6.5		2
5		B1658-562-0A0	Tension spring regulating arm asm.		1
6		SS-6121210-SP	Screw 3/16-28 L=12.0		(1)
7		SS-8150710-SP	Screw 15/64-28 L=7.0		1
8		SD-0600271-SP	Hinge screw D=6.00 H=2.7		1
9		B1657-562-000	Feed regulating rod		1
10		WZ-0641510-KP	Washer		1
11		SD-0600321-SP	Hinge screw D=6.0 H=3.2		1
12		B1663-562-000	Feed control lever stopper		1
13		SS-9111820-SP	Screw 11/64-40 L=18.0		1
14		NS-6110530-SP	Nut 11/64-40		1
15		SS-9151440-CP	Screw 15/64-28 L=14		1
16		WP-0621016-SD	Washer 6.2 x 13.0 x 1.0		1
17		PS-0500202-KP	Spring pin 5.0 x 20		1
18		PS-0500202-KP	Spring pin 5.0 x 20		1
19		B1662-562-000	Collar		1
20		B1624-555-000	Reverse feed control lever		1
21		SS-8660970-TP	Screw 1/4-40 L=8.5		1
22		SS-9660940-SP	Screw 1/4-40 L=8.5		1
23		B1654-562-000	Feed changing arm		1
24		SS-7151120-SP	Screw 15/64-28 L=11.0		1
25		SS-8151280-SP	Screw 15/64-28 L=12.0		1
26		SS-6121030-SP	Screw 3/16-28 L=10.0		1
27		B1656-562-000	Feed changing shaft (B)		1
28		B1655-562-000	Feed changing shaft base (B)		1
29		SS-8150710-SP	Screw 15/64-28 L=7.0		1
30		SM-6081542-CP	Screw M8 x 1.25 L=15		2
31		B1645-562-000	Feed regulating link		1
32		SS-8110750-SP	Screw 11/64-40 L=6.5		1
33		B1641-562-000	Feed regulating arm shaft		1
34		B1642-562-000	Feed regulating arm pin		1
35		B1647-122-000	Suspension bracket (A)		1
36		SS-8150710-SP	Screw 15/64-28 L=7.0		1
37		B2007-232-000	Tension spring		1
38		B1659-562-000	Tension spring suspension (B)		1
39		WP-0371016-SD	Washer 3.7 x 8.0 x 1.0	D.9/81	-
40		SS-4091010-SP	Screw 9/64-40 L=10.0	D.9/81	-
		SS-7090710-SP	Screw 9/64-40 L=6.8	A.9/81	1
41		SS-9111820-SP	Screw 11/64-40 L=18.0		1
42		NS-6110530-SP	Nut 11/64-40		1
43		B1644-562-0A0	Feed regulating pin asm.		1
44		CQ-2020000-00	Oil wick		(0.1)
45		B1667-562-000	Feed limiting plate		1
46		SS-9121340-CP	Screw 3/16-28 L=13.0		2
47		WP-0480856-SP	Washer 4.8 x 8.4 x 0.8		2
48		B1640-562-000	Feed regulating arm		1
49		SS-7151210-SP	Screw 15/64-28 L=12.0		1
50		SS-8110520-TP	Screw 11/64-40 L=4.5		1
51		SS-8110750-SP	Screw 11/64-40 L=6.5		1
52		SS-8110750-SP	Screw 11/64-40 L=6.5		1
53		B1643-562-000	Bushing, for arm shaft		1
54		SS-8110510-SP	Screw 11/64-40 L=5.0		1
55		B1653-562-000	Feed changing shaft (A)		1
56		B1414-155-000	Slide block		1
57		SS-7090540-SP	Screw 9/64-40 L=5.0		1
58		B1651-562-0A0	Feed changing fork asm.		1
59		SS-9151630-CP	Screw 15/64-28 L=15.5		(1)
60		PS-0300201-KP	Spring pin 3.0 x 20		1
61		B1652-562-000	Feed changing shaft base (A)		1
62		SM-6081542-CP	Screw M8 x 1.25 L=15		2

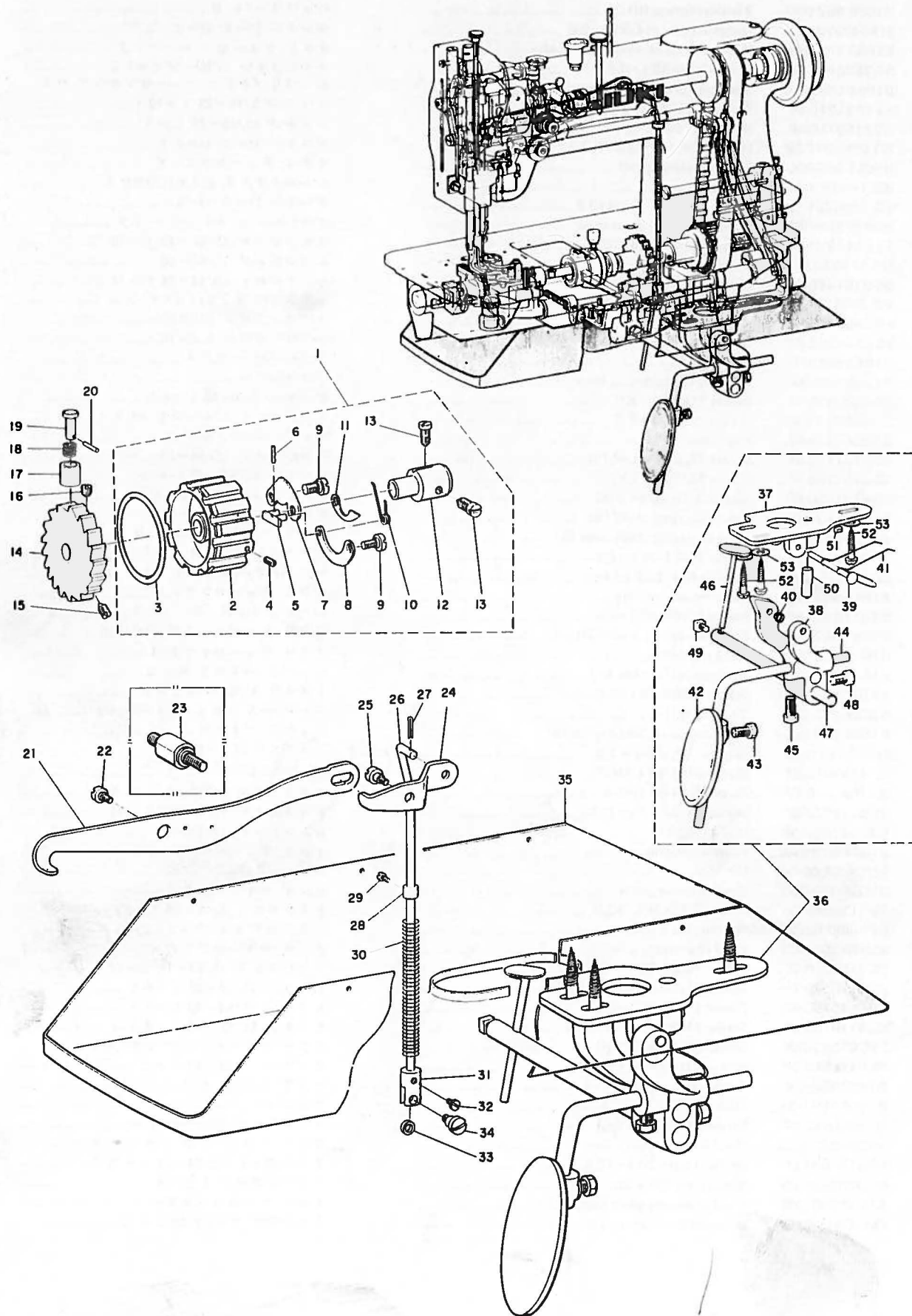

7. SAFETY CLUTCH MECHANISM, KNEE LIFTER COMPONENTS

安全装置、膝上げ関係

Ref. No.	Note	Part No.	Description	E.C.	品名	Amt. Req.
	注記	品番		変更年月		数量
1		B1303-055-AA0	Sprocket wheel lower asm.		シタ スプロケット アンゼンソーチ	1
2		B1303-055-A00	Sprocket wheel, lower		シタ スプロケット	(1)
3		B1214-019-000	Sprocket ring		スプロケット リング	(1)
4		SS-8090540-SP	Screw 9/64-40 L=5.0	D.8/75	SS-8090410-SP	-
		SS-8090410-SP	Screw 9/64-40 L=3.5	A.8/75	トメネジ 9/64-40 L=3.5	(1)
5		B1310-055-000	Safety clutch small link		アンゼンソーチ ショーリンク	(1)
6		B1314-055-000	Safety clutch small link pin		アンゼンソーチ ショーリンク ピン	(1)
7		B1307-055-000	Safety clutch hook		アンゼンソーチ ツメ	(1)
8		B1305-055-000	Safety clutch spring	D.8/75	B1305-055-000-A	-
		B1305-055-000-A	Safety clutch spring	A.8/75	アンゼンソーチ バネ	(1)
9		SD-0640322-TP	Hinge screw D=6.35 H=3.2		ダンネジ D=6.35 H=3.2	(2)
10		B1309-055-000	Safety clutch counter-hook spring		アンゼンソーチ ギャク ツメ バネ	(1)
11		B1308-055-000	Safety clutch counter-hook		アンゼンソーチ ギャク ツメ	(1)
12		B1311-055-000	Safety clutch body		アンゼンソーチ ウケ	(1)
13		B1316-055-000	Clamp screw	D.1/76	SS-7661110-TH	-
		SS-7661110-TH	Screw 1/4-40 L=11.0	A.1/76	トメネジ 1/4-40 L=11.0	(2)
14		B1314-057-000	Safety clutch ratchet gear		アンゼンソーチ ラチェット ギヤー	1
15		SS-8151780-SP	Screw 15/64-28 L=17.0		トメネジ 15/64-28 L=17	1
16		SS-8152080-SP	Screw 15/64-28 L=19.5		トメネジ 15/64-28 L=19.5	1
17		B1313-055-000	Safety clutch knob sleeve		アンゼンソーチ ボタン ツツ	1
18		B1639-051-000	Spring		オシボタン バネ	1
19		B1312-055-000	Safety clutch knob		アンゼンソーチ オシボタン	1
20		PS-0200102-KH	Spring pin 2.0 x 10		スプリングピン 2.0×10	1
21		B3409-053-000	Knee lifter front lever		ヒザアゲ マエテコ	1
22		SD-0790361-SP	Hinge screw D=7.94 H=3.6		ダンネジ D=7.94 H=3.6	1
23	06	B3418-562-000	Lump set screw		ランプ トリツケネジ	1
24		B3410-051-000	Knee lifter rear lever		ヒザアゲ ウシロ テコ	1
25		SD-0790361-SP	Hinge screw D=7.94 H=3.6		ダンネジ D=7.94 H=3.6	1
26		B3413-053-000	Rear lifting bar		ウシロ ツリポー	1
27		PD-0231100-0B	Cotter pin 2.3 x 11		ワリピン 2.3×11	1
28		CS-0510713-SC	Retaining collar D=5.1 W=7		スラストウケ D=5.1 W=7	1
29		SS-7110540-SP	Screw 11/64-40 L=5.0		マルヒラネジ 11/64-40 L=5	1
30		B3414-051-000	Rear lifting bar spring		ウシロ ツリポー オシバネ	1
31		B3416-051-000	Rear lifting bar roller holder		ウシロ ツリポー コロササエ	1
32		SS-7110510-SP	Screw 11/64-40 L=5.0		マルヒラネジ 11/64-40 L=5	1
33		B3417-051-000	Rear lifting bar roller		ウシロ ツリポー コロ	1
34		SD-0550801-SP	Hinge screw D=5.50 H=8.0		ダンネジ D=5.50 H=8	1
35		B8217-053-000	Drip pan		アブラウケ	1
36		B3401-027-0B0	Knee lifter asm.		ヒザアゲソーチ クミ	1
37		B3401-027-000	Knee driving shaft mounting base		ヒザアゲダイ	(1)
38		B3402-027-000	Knee driving bracket		ヒザアゲ タイ	(1)
39		B3408-027-000	Knee driving shaft		ヒザアゲ ジク	(1)
40		B3404-027-000	Spring		ヒザアゲ ブラケット バネ	(1)
41		B3409-027-000	Knee driving spring		ヒザアゲ バネ	(1)
42		B3407-027-000	Knee press plate		ヒザアテイタ	(1)
43		SM-9081620-SE	Screw		6 カクボルト	(1)
44		B3403-027-000	Knee press plate rod		ヒザアテイタ ジク	(1)
45		SS-9201813-CN	Screw 5/16-18 L=18.0		6 カクボルト 5/16-18 L=18	(1)
46		B3405-027-0A0	Knee lift plate asm.		ツキアゲイタ	(1)
47		B3410-027-000	Knee press shaft		ツキアゲ イタジク	(1)
48		SS-9201813-CN	Screw 5/16-18 L=18.0		6 カクボルト 5/16-18 L=18	(1)
49		B3406-027-000	Bolt		ツキアゲイタ カクボルト	(1)
50		B3411-027-000	Stopper pin		ストッパー ピン	(1)
51		SS-8150710-SN	Screw 15/64-28 L=7.0		トメネジ 15/64-28 L=7	(1)
52		SK-3623200-SC	Wood screw D=6.2 L=32		マルモクネジ D=6.2 L=32	(3)
53	☆	WP-0851216-SC	Washer 8.5 x 18.0 x 1.2	D.8/83	WP-0850002-SC	-
	☆	WP-0850002-SC	Washer 8.5 x 18.0 x 1.6	A.8/83	ワカネ 8.5×18.0×1.6	(3)

Note (注記) 06 Special order part for LU-562, LU-563 LU-562、LU-563用特別注文部品

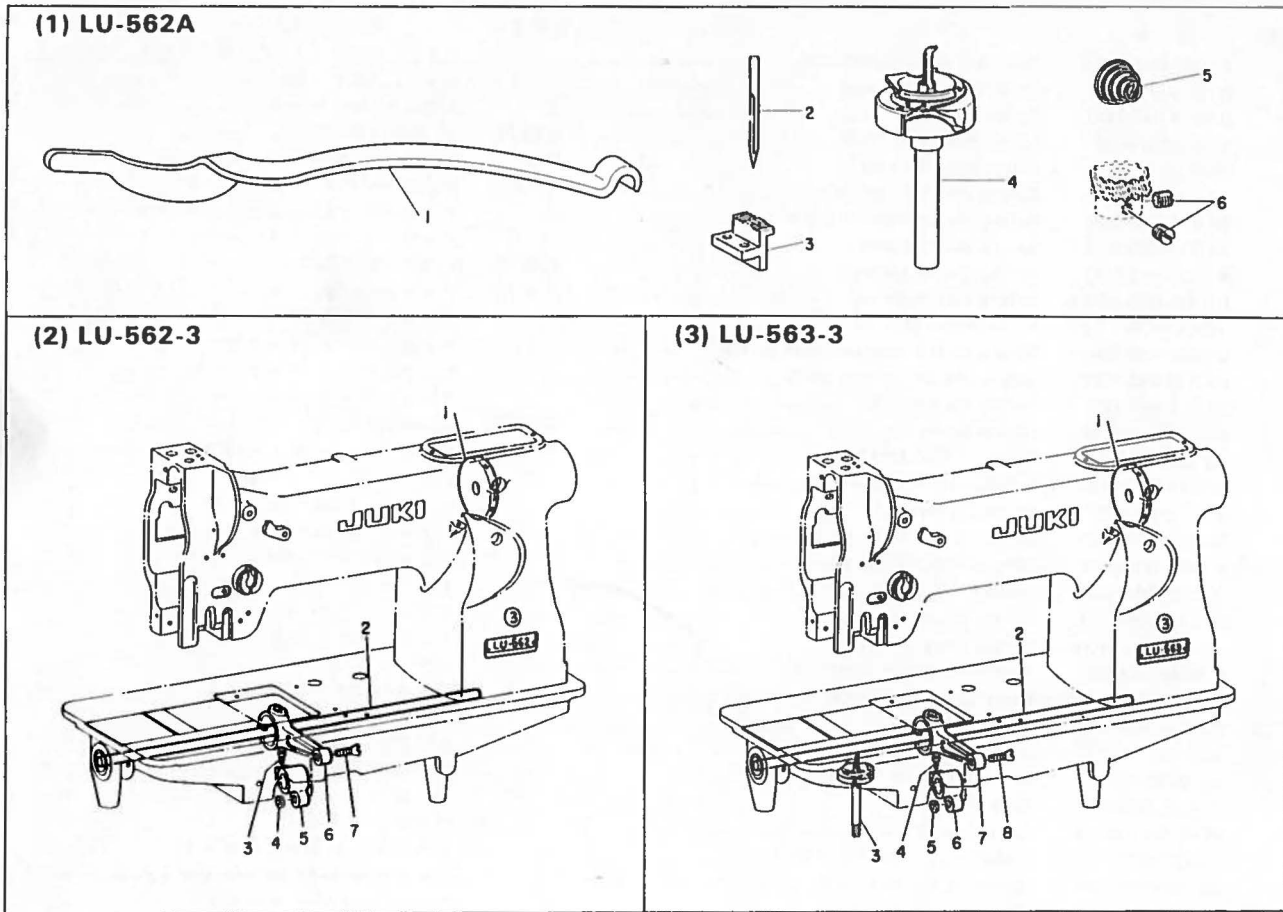

Ref. No.	Note	Part No.	Description	E.C.	Amt. Req.
	注記	品番		変更年月	数量
(1) LU-562A (For light weight materials)					
1		B1505-053-B00	Adjusting plate spring (B)	LU-562A (薄物用)	1
2		MDi-300B1600	Needle D1 x 3 #16	オサエ チョーセツイタ バネ B	1
3		B1613-053-B00	Feed dog (B)	ハリ D1 x 3 #16	1
4		B1830-051-0A0	Hook asm.	オクリバ B	1
5		B3129-051-000	Tension spring	カマ クミ	1
6		SS-8660530-TP	Screw 1/4-40 L=4.5	イトチョーシバナ	1
				トメネジ 1/4-40 L=4.5	2
(2) LU-562-3 (For long stitch length, without reverse feed)					
1		B1220-055-000	Stitch graduator	LU-562-3(荒送り用、返し縫ナシ)	1
2		D1801-562-C00	Hook driving shaft	オクリ メモリイタ	1
3		SS-6121610-SP	Screw 3/16-28 L=15.5	シタジク	1
4		NS-6680410-SP	Nut 9/32-28	ヒラネジ 3/16-28 L=15.5	1
5		B1616-055-000	Feed rock shaft crank	6 カクナット 9/32-28	1
6		B1614-057-000	Feed rock shaft connecting rod	スイヘイ オクリウデ	1
7		B1621-012-A00	Taper screw	オクリロッド	1
				テーバネジ	1
(3) LU-563-3 (For long stitch length, without reverse feed)					
1		B1220-055-000	Stitch graduator	LU-563-3 (荒送り用、返し縫ナシ)	1
2		D1801-562-C00	Hook driving shaft	オクリ メモリイタ	1
3		B1830-563-BA0	Hook asm.	シタジク	1
4		SS-6121610-SP	Screw 3/16-28 L=15.5	カマ クミ	1
5		NS-6680410-SP	Nut 9/32-28	ヒラネジ 3/16-28 L=15.5	1
6		B1616-055-000	Feed rock shaft crank	6 カクナット 9/32-28	1
7		B1614-057-000	Feed rock shaft connecting rod	スイヘイ オクリウデ	1
8		B1621-012-A00	Taper screw	オクリ ロッド	1
				テーバネジ	1

9. BELT COVER COMPONENTS (SPECIAL ORDER PARTS)

ベルトカバー関係 (特別注文部品)

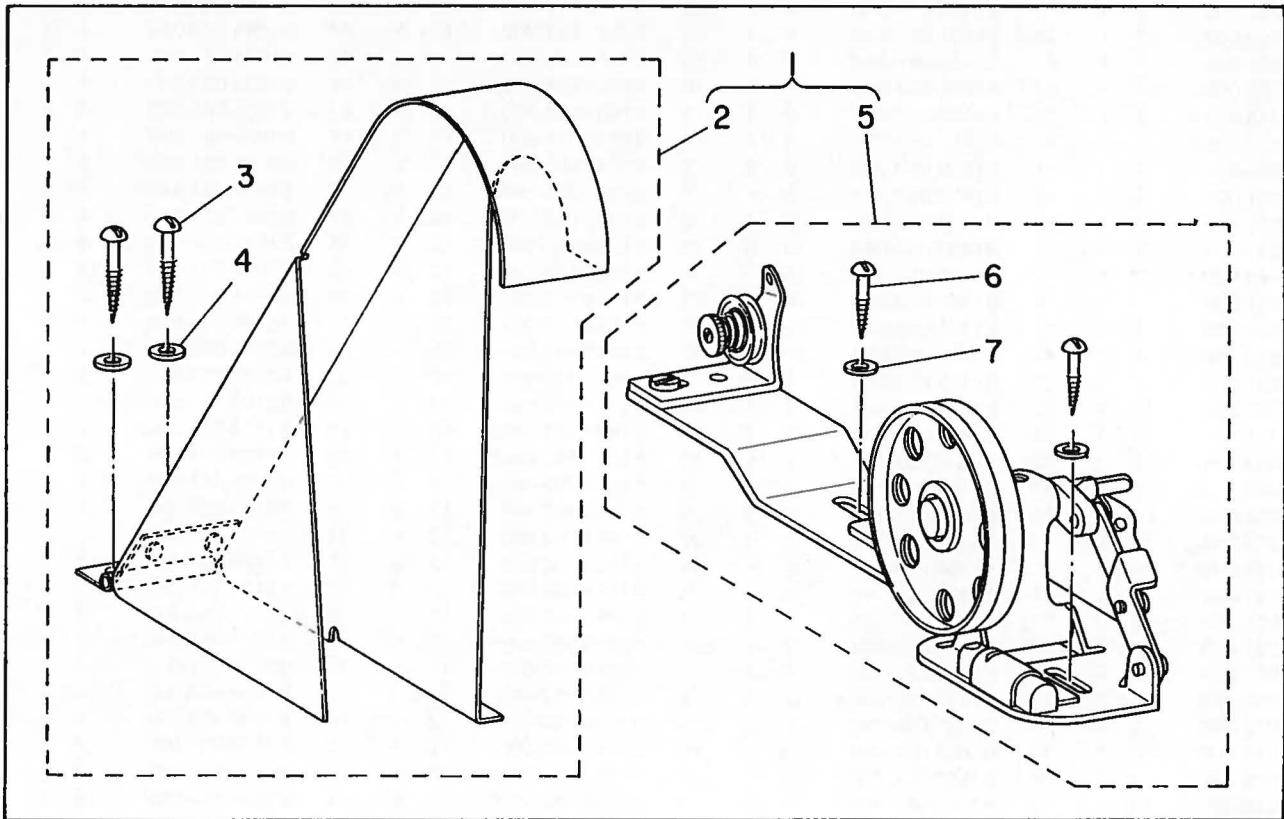

Ref. No.	Note	Part No.	Description	E.C.	品名	Amt. Req.
	注記	品番		変更年月		数量
1		B8230-562-0C0	Belt cover and thread winder asm.		ベルトカバー イトマキソウチ クミ	1
2		B8230-562-0B0	Belt cover asm.		ベルトカバー クミ	(1)
3		SK-3513200-SC	... Installing round wooden screw		ベルトカバー トリツケ マルモクネジ	(2)
4		WP-0560860-SE	... Washer	D.10/80	WP-0501016-SC	-
		WP-0501016-SC	... Washer	A.10/80	ザガネ	(2)
5		B3201-562-0B0	Bobbin winder asm.		イトマキソウチ クミ	(1)
6		SK-3482500-SC	... Installing round wooden screw		イトマキソウチ トリツケ マルモクネジ	(2)
7		WP-0501016-SC	... Washer		イトマキソウチ トリツケ マルモクネジ ザガネ	(2)

10. NUMERICAL INDEX OF PARTS

索引

Part No. 品番	Page 頁	Item 項目	Ref. No.	Part No. 品番	Page 頁	Item 項目	Ref. No.	Part No. 品番	Page 頁	Item 項目	Ref. No.	Part No. 品番	Page 頁	Item 項目	Ref. No.
EXCLUSIVE PARTS 專用部品				B1434-051-0A0	8	4	53	B1625-057-0A0	6	3	51	B1843-563-000	6	3	40
B1103-051-000	2	1	8	B1435-051-0A0	8	4	58	B1626-562-000	6	3	45	B1844-563-000	2	1	55
B1109-053-000-A	2	1	48	B1437-051-000	8	4	46	B1627-562-000	10	5	44	B1846-563-000	2	1	56
B1109-562-000	2	1	47	B1438-051-0A0	8	4	45	B1636-055-000	6	3	46	B1905-053-0B0	4	2	1
B1111-563-000	2	1	53	B1455-053-000	8	4	10	B1637-055-000	6	3	48	B1905-053-000	4	2	2
B1112-053-000-A	2	1	45	B1456-053-000	8	4	9	B1639-051-000	6	3	47	B1905-563-0B0	4	2	10
B1113-053-000-A	2	1	46	B1457-055-000	8	4	7	B1639-051-000	14	7	18	B1905-563-000	4	2	11
B1114-051-000	2	1	21	B1458-053-000	8	4	6	B1640-562-000	12	6	48	B1906-051-0A0	4	2	3
B1128-051-000	2	1	16	B1459-053-00A	8	4	1	B1641-562-000	12	6	33	B1906-051-0A0	4	2	12
B1128-522-000	2	1	16	B1459-053-00B	8	4	2	B1642-057-000	10	5	47	B1907-051-0A0	4	2	5
B1129-051-000	2	1	5	B1460-053-0A0	10	5	30	B1642-562-000	12	6	34	B1907-051-0A0	4	2	14
B1129-563-000	2	1	6	B1460-053-00A	10	5	31	B1643-562-000	12	6	53	B2007-232-000	12	6	37
B1130-051-000	2	1	9	B1460-053-00B	10	5	33	B1644-562-0A0	12	6	43	B3101-053-000	2	1	1
B1131-562-000	2	1	11	B1461-053-0A0	10	5	38	B1645-562-000	12	6	31	B3106-019-000	2	1	2
B1132-562-000	2	1	44	B1462-053-000	10	5	37	B1646-562-0A0	10	5	53	B3121-053-0A0	2	1	25
B1140-051-000	2	1	3	B1465-053-000	8	4	4	B1647-122-000	12	6	35	B3122-053-000	2	1	26
B1150-051-000	2	1	22	B1466-053-000	8	4	25	B1647-562-000	10	5	51	B3123-051-000	2	1	40
B1152-051-000	2	1	23	B1466-053-000-A	8	4	25	B1648-562-0A0	10	5	62	B3124-051-0A0	2	1	30
B1155-053-000	2	1	19	B1467-053-00A	8	4	23	B1651-562-0A0	12	6	58	B3124-051-000	2	1	31
B1157-009-0A0	2	1	42	B1467-053-00B	8	4	21	B1652-562-000	12	6	61	B3125-012-000	2	1	36
B1158-562-000	10	5	39	B1467-053-00C	8	4	22	B1653-562-000	12	6	55	B3126-051-000	2	1	33
B1158-563-000	4	2	8	B1467-521-00C	8	4	22	B1654-562-000	12	6	23	B3127-051-000	2	1	29
B1202-051-0A0	4	2	27	B1468-053-000	8	4	24	B1655-562-000	12	6	28	B3128-051-000	2	1	39
B1203-051-000	4	2	32	B1469-053-000	8	4	20	B1656-562-000	12	6	27	B3129-051-000	15	8-1	5
B1205-051-000	4	2	30	B1470-053-C00	8	4	28	B1657-562-000	12	6	9	B3129-053-000	2	1	35
B1206-051-000	4	2	19	B1470-053-000	8	4	26	B1658-562-0A0	12	6	5	B3131-051-000	2	1	32
B1207-051-0A0	4	2	25	B1470-562-B00	8	4	27	B1659-562-000	12	6	38	B3132-051-000	2	1	34
B1210-051-0A0	4	2	17	B1471-562-000	10	5	19	B1660-562-000	12	6	3	B3134-051-000	2	1	27
B1213-012-000	8	4	18	B1501-040-000	10	5	5	B1662-562-000	12	6	19	B3137-051-0A0	2	1	37
B1213-012-000	10	5	40	B1502-051-000	10	5	24	B1663-562-000	12	6	12	B3138-051-000	2	1	13
B1214-019-000	4	2	38	B1503-051-A00	10	5	26	B1664-562-000	10	5	52	B3138-512-000	2	1	13
B1214-019-000	14	7	3	B1503-051-B00	10	5	3	B1666-562-000	12	6	1	B3201-562-0B0	16	9	5
B1216-051-0A0	4	2	43	B1504-051-0A0	10	5	28	B1667-562-000	12	6	45	B3401-027-0B0	14	7	36
B1216-051-000	4	2	44	B1505-053-B00	15	8-1	1	B1702-012-000	8	4	19	B3401-027-000	14	7	37
B1217-051-0A0	4	2	45	B1505-053-000	10	5	21	B1702-012-000	10	5	41	B3402-027-000	14	7	38
B1218-051-000	4	2	48	B1507-051-0A0	10	5	1	B1801-562-000	6	3	57	B3403-027-000	14	7	44
B1219-051-000	4	2	47	B1507-562-0A0	10	5	1	B1802-053-000	6	3	28	B3404-027-000	14	7	40
B1219-051-000	6	3	62	B1509-051-000	2	1	20	B1804-051-000	6	3	43	B3405-027-0A0	14	7	46
B1220-055-000	15	8-2	1	B1512-051-000	10	5	35	B1806-051-000	6	3	55	B3406-027-000	14	7	49
B1220-055-000	15	8-3	1	B1515-051-000	10	5	36	B1807-051-000	6	3	58	B3407-027-000	14	7	42
B1220-562-0A0	4	2	36	B1525-053-0A0	10	5	6-1	B1807-512-000	6	3	54	B3408-027-000	14	7	39
B1227-053-000	4	2	50	B1525-053-000	10	5	6	B1808-051-0A0	6	3	60	B3409-027-000	14	7	41
B1230-051-000	4	2	28	B1525-562-BA0	10	5	20-1	B1809-051-000	6	3	63	B3409-053-000	14	7	21
B1233-012-000	4	2	53	B1525-562-B00	10	5	20	B1811-051-000	6	3	15	B3410-027-000	14	7	47
B1301-051-000	4	2	42	B1601-562-000	10	5	57	B1811-563-000	6	3	38	B3410-051-000	14	7	24
B1302-051-000	4	2	39	B1602-055-0A0	10	5	8	B1812-051-000	6	3	17	B3411-027-000	14	7	50
B1303-055-AA0	14	7	1	B1602-055-000	10	5	9	B1814-051-000	6	3	6	B3413-053-000	14	7	26
B1303-055-A00	14	7	2	B1603-051-000	10	5	55	B1814-563-000	6	3	36	B3414-051-000	14	7	30
B1305-055-000	14	7	8	B1604-051-000	10	5	10	B1815-051-000	6	3	26	B3416-051-000	14	7	31
B1307-055-000	14	7	7	B1605-051-000	10	5	13	B1815-563-000	6	3	39	B3417-051-000	14	7	33
B1308-055-000	14	7	11	B1607-051-000	10	5	58	B1816-521-0A0	6	3	20	B3418-562-000	14	7	23
B1309-055-000	14	7	10	B1609-051-000	10	5	67	B1817-051-0A0	6	3	22	B3501-051-000	2	1	18
B1310-055-000	14	7	5	B1611-055-000	10	5	16	B1818-051-B00	6	3	25	B3542-581-000	2	1	50
B1311-055-000	14	7	12	B1613-053-B00	15	8-1	3	B1820-051-000	6	3	5	B8217-057-000	14	7	35
B1312-055-000	14	7	19	B1613-053-000	10	5	15	B1821-051-0A0	6	3	12	B8230-562-0B0	16	9	2
B1313-055-000	14	7	17	B1613-563-B00	10	5	18	B1822-051-000	6	3	8	B8230-562-0C0	16	9	1
B1314-055-000	14	7	6	B1613-563-000	10	5	15	B1822-563-000	6	3	37	B9117-051-000	6	3	3
B1314-057-000	14	7	14	B1613-563-000	10	5	17	B1823-051-0A0	6	3	1	B9117-563-000	6	3	32
B1316-055-000	14	7	13	B1614-057-000	15	8-2	6	B1824-051-000	6	3	9	D1201-055-B00	4	2	24
B1401-053-000	8	4	39	B1614-057-000	15	8-3	7	B1824-563-000	6	3	35	D1450-055-BA0	4	2	33
B1405-012-000	2	1	43	B1614-562-0B0	10	5	42	B1830-051-0A0	15	8-1	4	D1453-055-B00	8	4	17
B1408-051-000	4	2	16	B1614-562-000	10	5	43	B1830-055-0A0	6	3	4	D1454-055-BA0	8	4	11
B1411-053-0B0	8	4	33	B1616-055-000	15	8-2	5	B1830-563-BA0	6	3	42	D1455-055-B00	8	4	13
B1412-051-000	8	4	35	B1616-055-000	15	8-3	6	B1830-563-BA0	15	8-3	3	D1456-055-B00	8	4	14
B1414-155-000	12	6	56	B1616-562-0A0	10	5	64	B1830-563-0A0	6	3	33	D1457-055-B00	8	4	15
B1419-053-000	8	4	41	B1621-012-A00	15	8-2	7	B1831-055-000	6	3	21	D1458-055-B00	8	4	16
B1420-053-000	8	4	30	B1621-012-A00	15	8-3	8	B1838-563-000	2	1	54	D1801-562-C00	15	8-2	2
B1421-051-000	8	4	31	B1622-057-000	10	5	46	B1839-053-000	2	1	51	D1801-562-C00	15	8-3	2
B1423-051-000	8	4	36	B1623-057-000	10	5	45	B1839-563-000	2	1	58				
B1425-051-0A0	8	4	44	B1623-563-000	10	5	45-1	B1840-051-0A0	6	3	30	OIL WICK			
B1429-051-0A0	8	4	47	B1624-055-000	6	3	50	B1841-053-000	2	1	52	CQ-2020000-00	4	2	4
B1431-051-0A0	8	4	49	B1624-555-000	12	6	20	B1841-563-000	2	1	59	CQ-2020000-00	4	2	6

Part No. 品番	Page 頁	Item 項目	Ref. No.	Part No. 品番	Page 頁	Item 項目	Ref. No.	Part No. 品番	Page 頁	Item 項目	Ref. No.	Part No. 品番	Page 頁	Item 項目	Ref. No.	
CQ-2020000-00	4	2	13	SD-0470281-SP	2	1	28	SS-7110510-SP	2	1	53	SS-8151230-SP	4	2	37	
CQ-2020000-00	4	2	15	SD-0550801-SP	14	7	34	SS-7110510-SP	2	1	53	SS-8151230-SP	6	3	34	
CQ-2020000-00	4	2	18	SD-0600271-SP	12	6	8	SS-7110510-SP	2	1	57	SS-8151280-SP	12	6	25	
CQ-2020000-00	4	2	26	SD-0600321-SP	12	6	11	SS-7110510-SP	14	7	32	SS-8151350-SP	4	2	31	
CQ-2020000-00	4	2	29	SD-0630241-SD	2	1	24	SS-7110540-SP	14	7	29	SS-8151350-SP	4	2	49	
CQ-2020000-00	6	3	2	SD-0640322-TP	14	7	9	SS-7110720-SP	2	1	15	SS-8151550-SP	6	3	44	
CQ-2020000-00	6	3	13	SD-0790361-SP	14	7	22	SS-7111310-SP	10	5	32	SS-8151770-SP	10	5	50	
CQ-2020000-00	8	4	54	SD-0790361-SP	14	7	25	SS-7111410-SP	10	5	65	SS-8151780-SP	4	2	52	
CQ-2020000-00	8	4	56	SD-0790801-SP	8	4	51	SS-7150740-SP	4	2	9	SS-8151780-SP	10	5	49	
CQ-2020000-00	10	5	54	SD-0800481-SP	10	5	23	SS-7150940-SP	4	2	9	SS-8151780-SP	14	7	15	
CQ-2020000-00	10	5	63	SD-0801601-SP	10	5	22	SS-7151120-SP	12	6	24	SS-8152030-SP	4	2	51	
CQ-2020000-00	12	6	44	SD-095080A-SP	8	4	55	SS-7151210-SP	12	6	49	SS-8152030-SP	6	3	29	
								SS-7161640-SP	8	4	12	SS-8152030-SP	6	3	59	
THRUST COLLAR	スラストカラー			SCREW	ネジ			SS-7620750-SP	12	6	4	SS-8152030-SP	10	5	68	
CS-0510713-SC		14	7	28	SK-3482500-SC	16	9	6	SS-7661110-TH	14	7	13	SS-8152080-SP	14	7	16
CS-1401010-SC		10	5	60	SK-3513200-SC	16	9	3	SS-7681750-TP	4	2	23	SS-8660530-TP	4	2	34
					SK-3623200-SC	14	7	52	SS-7681750-TP	4	2	41	SS-8660530-TP	6	3	23
NEEDLE	針				SM-6081542-CP	12	6	30	SS-7762840-SP	6	3	16	SS-8660530-TP	15	8-1	6
MC-3515016-00		8	4	40-1	SM-6081542-CP	12	6	62	SS-8081050-TH	10	5	47	SS-8660670-SP	6	3	24
MDi-300B1600		15	8-1	2	SM-9081620-SE	14	7	43	SS-8081210-TH	10	5	47	SS-8660830-TP	6	3	21
MDi-300B2300		8	4	40	SS-2090710-SP	2	1	7	SS-8090530-TP	6	3	64	SS-8660970-TP	4	2	35
					SS-2090710-SP	2	1	10	SS-8090540-SP	14	7	4	SS-8660970-TP	12	6	21
NUT	ナット				SS-2110920-TP	2	1	49	SS-8110510-SP	2	1	17	SS-8680540-SP	4	2	20
NS-6080210-SP		10	5	48	SS-3090610-SP	2	1	4	SS-8110510-SP	6	3	52	SS-8680730-SP	4	2	21
NS-6110310-SP		8	4	3	SS-3090610-SP	2	1	12	SS-8110510-SP	10	5	56	SS-8681650-TP	4	2	22
NS-6110420-SP		6	3	14	SS-4080610-SP	2	1	38	SS-8110510-SP	12	6	54	SS-8681650-TP	4	2	40
NS-6110420-SP		6	3	41	SS-4091010-SP	12	6	40	SS-8110520-TP	10	5	66	SS-9111010-SP	8	4	38
NS-6110530-SP		8	4	16	SS-5080710-SP	10	5	14	SS-8110520-TP	12	6	50	SS-9111820-SP	12	6	13
NS-6110530-SP		12	6	14	SS-6081220-TP	10	5	47	SS-8110750-SP	6	3	53	SS-9111820-SP	12	6	41
NS-6110530-SP		12	6	42	SS-6090620-SP	6	3	11	SS-8110750-SP	12	6	32	SS-9121340-CP	12	6	46
NS-6160520-SP		8	4	52	SS-6090910-TP	10	5	7	SS-8110750-SP	12	6	51	SS-9151440-CP	10	5	11
NS-6620310-SP		8	4	48	SS-6110710-TP	8	4	29	SS-8110750-SP	12	6	52	SS-9151440-CP	12	6	15
NS-6660430-SP		8	4	8	SS-6111140-SP	8	4	5	SS-8111251-SP	2	1	41	SS-9151630-CP	12	6	59
NS-6680410-SP		15	8-2	4	SS-6121030-SP	12	6	26	SS-8150410-SP	10	5	61	SS-9161610-SP	8	4	12
NS-6680410-SP		15	8-3	5	SS-6121210-SP	12	6	6	SS-8150580-SP	6	3	31	SS-9201813-CN	14	7	45
NS-6700420-SP		8	4	57	SS-6121610-SP	15	8-2	3	SS-8150710-SN	1	7	51	SS-9201813-CN	14	7	48
					SS-6121610-SP	15	8-3	4	SS-8150710-SP	4	2	46	SS-9660940-SP	12	6	22
					SS-6151440-SP	8	4	50	SS-8150710-SP	6	3	18				
PIN	ピン				SS-6151920-SP	8	4	59	SS-8150710-SP	6	3	27	PLUG	止メ栓		
PD-0231100-0B		14	7	27	SS-6153040-SP	6	3	19	SS-8150710-SP	10	5	59	TA-0570601-MO	4	2	26-1
PS-0200102-KH		14	7	20	SS-7060310-SP	8	4	42	SS-8150710-SP	12	6	7				
PS-0300201-KP		12	6	60	SS-7080510-SP	8	4	43	SS-8150710-SP	12	6	29	WASHER	座金		
PS-0500202-KP		12	6	17	SS-7080510-TP	8	4	43	SS-8150710-SP	12	6	36	WP-0371016-SD	6	3	10
PS-0500202-KP		12	6	18	SS-7090520-SP	2	1	14	SS-8150710-SP	12	6	61	WP-0371016-SD	12	6	39
PT-0201200-S0		10	5	34	SS-7090520-SP	6	3	56	SS-8151150-SP	4	2	7	WP-0480856-SP	8	4	37
					SS-7090540-SP	12	6	57	SS-8151150-SP	6	3	7	WP-0480856-SP	12	6	47
SNAP RING	Eリング				SS-7090610-SP	2	1	2	SS-8151150-SP	10	5	4	WP-0501016-SC	16	9	4
RE-0500000-K0		6	3	49	SS-7090710-SP	12	6	40	SS-8151150-SP	10	5	25	WP-0501016-SC	16	9	7
					SS-7090910-SP	8	4	34	SS-8151150-SP	10	5	27	WP-0560860-SE	16	9	4
BEARING	ベアリング				SS-7090910-SP	10	5	2	SS-8151150-SP	10	5	59	WP-0621016-SD	12	6	16
SB-1150002-00		4	2	47	SS-7090910-SP	10	5	29	SS-8151160-SP	8	4	32	WP-0753016-SZ	6	3	17
SB-1150002-00		6	3	62	SS-7091310-SP	10	5	2					WP-0850002-SC	14	7	53
					SS-7110410-SP	2	1	53					WP-0851216-SC	14	7	53
HINGE SCREW	段ネジ												WS-0651510-KP	10	5	12
SD-0400201-SD		12	6	2									WP-0851216-SC	14	7	53
													WS-0651510-KP	10	5	12
													WZ-0641510-KP	12	6	10

JUKI

JUKI CORPORATION

HEAD OFFICE
2-1, 8-CHOME, KOKURYO-CHO,
CHOFU-CITY, TOKYO, JAPAN

BUSINESS OFFICE
23-3, KABUKI-CHO 1-CHOME,
SHINJUKU-KU, TOKYO 160, JAPAN

CABLE : JUKI TOKYO
TELEX : J22967, 232-2301
PHONE : 03(205)1188, 1189, 1190

JUKI 株式会社

〒182 東京都調布市国領町8-2-1
TEL. 03-480-1111(代表)
工業製品販売部
TEL. 03-480-1113(ダイヤルイン)

